



PRIBOR

BENMAN



www.gartner.rs

**BEST
SELLER** **MUST
HAVE**



HSS SPIRALNA VALJANA BURGIJA, DIN 338

ŠIFRA	PREČNIK	PAKET	€/KOM.
74500	1,00mm	10	0,26
74501	1,50mm	10	0,26
74502	2,00mm	10	0,26
74744	2,25mm	10	0,30
74503	2,50mm	10	0,30
74745	2,75mm	10	0,30
74504	3,00mm	10	0,30
74505	3,25mm	10	0,34
74506	3,50mm	10	0,34
74746	3,75mm	10	0,36
74507	4,00mm	10	0,36
74508	4,25mm	10	0,50
74509	4,50mm	10	0,50
74747	4,75mm	10	0,60
74510	5,00mm	10	0,60
74748	5,25mm	10	0,80
74511	5,50mm	10	0,80
74749	5,75mm	10	0,90
74512	6,00mm	10	0,90
74513	6,50mm	10	1,10
74514	7,00mm	10	1,30
74515	7,50mm	10	1,40
74516	8,00mm	5	1,80
74517	8,50mm	5	2,10
74518	9,00mm	5	2,30
74519	9,50mm	5	2,60
74520	10,00mm	5	2,80
74521	10,50mm	5	3,20
74522	11,00mm	5	3,60
74523	11,50mm	5	3,90
74524	12,00mm	5	4,40
74525	12,50mm	5	5,00
74526	13,00mm	5	5,40
74527	14,00mm	5	6,20
74528	15,00mm	5	6,60
74529	16,00mm	5	7,50
74530	18,00mm	1	10,50
74531	20,00mm	1	13,50



- +20% brže bušenje usled naoštrenog vrha
- +40% povećana snaga u odnosu na obične burgije.
- Napravljeno od čelika visokog kvaliteta (HSS 9341)
- Posebno termički obrađeno radi zaštite od lomljenja posebno kod manjih veličina (1-6)

**+20%
FASTER**

**+40%
MORE
DURABLE**



**BEST
SELLER**



HSS SPIRALNA POTPUNO BRUŠENA BURGIJA, DIN 338

ŠIFRA	PREČNIK	PAKET	€/KOM.
74151	1,00mm	10	0,40
74152	1,50mm	10	0,40
74153	2,00mm	10	0,40
74154	2,50mm	10	0,40
74155	3,00mm	10	0,50
74156	3,25mm	10	0,54
74157	3,50mm	10	0,56
74158	4,00mm	10	0,62
74159	4,25mm	10	0,80
74160	4,50mm	10	0,80
74161	5,00mm	10	0,90
74162	5,50mm	10	1,20
74163	6,00mm	10	1,30
74164	6,50mm	5	1,60
74165	7,00mm	5	1,90
74166	7,50mm	5	2,10
74167	8,00mm	5	2,60
74168	8,50mm	5	2,90
74169	9,00mm	5	3,40
74170	9,50mm	5	3,60
74171	10,00mm	5	4,10
74172	10,50mm	5	4,70
74173	11,00mm	5	5,20
74174	11,50mm	5	6,10
74175	12,00mm	5	6,70
74176	12,50mm	5	7,50
74177	13,00mm	5	8,00
74178	14,00mm	1	9,00
74179	15,00mm	1	10,50
74180	16,00mm	1	12,50
74181	17,00mm	1	14,00
74182	18,00mm	1	16,00
74183	19,00mm	1	19,00
74184	20,00mm	1	20,00



- 50% brže bušenje usled naoštrenog vrha (135°)
- Patentirana neklizajuća vodica šiljka
- +40% veća otpornost u odnosu na obične burgije
- Napravljeno od čelika visokog kvaliteta

**+50%
FASTER**

**+40%
MORE
RESISTANT**



*KOLIČINA PRI VIŠESTRUKOJ PORUČBINI

NICE
TO HAVE

HSS SPIRALNA
POTPUNO BRUŠENA
BURGIJA, DIN 338,
BLISTER PAKOVANJE



ŠIFRA	PREČNIK	PAKET	€/PAK.
71685	1,00mm	3	0,90
71686	1,50mm	3	0,90
71687	2,00mm	3	1,00
71688	2,25mm	3	1,10
71689	2,50mm	3	1,10
71690	3,00mm	2	1,10
71691	3,25mm	2	1,30
71692	3,50mm	2	1,30
71693	4,00mm	1	0,80
71694	4,25mm	1	0,90
71695	4,50mm	1	0,90
71696	5,00mm	1	1,10
71697	5,50mm	1	1,40
71698	6,00mm	1	1,50
71699	6,50mm	1	1,60
71700	7,00mm	1	2,00
71701	7,50mm	1	2,20
71702	8,00mm	1	2,60
71703	8,50mm	1	2,80
71704	9,00mm	1	3,30
71705	9,50mm	1	3,60
71706	10,00mm	1	4,20
71707	10,50mm	1	4,40
71708	11,00mm	1	5,40
71709	11,50mm	1	6,00
71710	12,00mm	1	6,60
71711	12,50mm	1	7,40
71712	13,00mm	1	8,00



- 50% brže bušenje usled naoštrenog vrha (135°)
- Posebna patentirana neklizajuća vodica šiljka
- +40% veća otpornost u odnosu na obične burgije
- Napravljena od čelika

**+50%
FASTER**

**+40%
MORE
RESISTANT**

BEST
SELLER

MUST
HAVE

HSS+CO5% KOBALTNA
SPIRALNA POTPUNO
BRUŠENA BURGIIJA,
DIN 338, BLISTER
PAKOVANJE



ŠIFRA	PREČNIK	PAKET	€/PAK.
71713	1,00mm	3	1,60
71714	1,50mm	3	1,60
71715	2,00mm	3	1,80
71716	2,50mm	3	2,10
71717	3,00mm	2	1,70
71718	3,25mm	2	2,10
71719	3,50mm	2	2,10
71720	4,00mm	1	1,30
71721	4,25mm	1	1,50
71722	4,50mm	1	1,50
71723	5,00mm	1	1,70
71724	5,50mm	1	2,10
71725	6,00mm	1	2,20
71726	6,50mm	1	2,60
71727	7,00mm	1	3,20
71728	7,50mm	1	3,60
71729	8,00mm	1	3,90
71730	8,50mm	1	4,80
71731	9,00mm	1	5,20
71732	9,50mm	1	5,80
71733	10,00mm	1	6,30
71734	10,50mm	1	7,50
71735	11,00mm	1	8,60
71736	11,50mm	1	9,20
71737	12,00mm	1	10,00
71738	12,50mm	1	11,00
71739	13,00mm	1	11,50



- 30% veća otpornost u odnosu u odnosu na obične kobaltne burgije
- 30% brže bušenje usled naoštrenog vrha (135°)
- Posebna patentirana neklizajuća vodica šiljka
- Patentirani navoj za dodatnu brzinu preciznost i otpornost

**+30%
FASTER**

**+30%
MORE
RESISTANT**

DIN 338 HSS COBALT 5%



BEST
SELLER

MUST
HAVE

HSS+CO5% KOBALTNA
SPIRALNA POTPUNO
BRUŠENA BURGIIJA,
DIN 338



ŠIFRA	PREČNIK	PAKET	€/KOM.
74532	1,00mm	10	0,50
74533	1,50mm	10	0,60
74534	2,00mm	10	0,60
74535	2,50mm	10	0,70
74536	3,00mm	10	0,80
74537	3,25mm	10	1,00
74538	3,50mm	10	1,00
74539	4,00mm	10	1,40
74540	4,25mm	10	1,80
74541	4,50mm	10	1,80
74542	5,00mm	10	1,90
74543	5,50mm	10	2,20
74544	6,00mm	10	2,30
74545	6,50mm	10	2,90
74546	7,00mm	10	3,20
74547	7,50mm	10	3,80
74548	8,00mm	10	3,90
74549	8,50mm	10	5,00
74550	9,00mm	10	5,70
74551	9,50mm	10	6,50
74552	10,00mm	10	6,70
74553	10,50mm	5	8,20
74554	11,00mm	5	8,50
74555	11,50mm	5	9,80
74556	12,00mm	5	10,60
74557	12,50mm	5	11,50
74558	13,00mm	5	12,00
74559	14,00mm	1	18,00
74560	15,00mm	1	22,00
74561	16,00mm	1	25,00
74090	18,00mm	1	33,00
74092	20,00mm	1	46,00



- 50% brže od obične kobaltne burgije
- Posebna patentirana neklizajuća vodica šiljka
- Patentirani navoj za dodatnu brzinu preciznost i otpornost

**+50%
FASTER**

DIN 338 HSS COBALT 5%



*KOLIČINA PRI VIŠESTRUKOJ PORUČBINI

NEW **MUST HAVE**



**HSS SPIRALNA POTPUNO BRUŠENA BURGIJA,
SA HEX PRIHVATOM 1/4"**

ŠIFRA	PREČNIK	UKUPNA DUŽINA	DUŽINA MREŽE	PAKET	KUTIJA	€/PAK.
72106	2mm	69mm	24mm	2	250	1,70
72107	3mm	81mm	33mm	2	250	2,20
72108	4mm	95mm	43mm	2	125	2,60
72109	5mm	106mm	52mm	1	125	1,80
72110	6mm	113mm	57mm	1	100	2,30
72111	8mm	117mm	75mm	1	100	3,80

- 50% brže bušenje usled naoštrenog vrha 135°
- 30% veća otpornost u odnosu na obične burgije

+50%
FASTER

+30%
MORE
RESISTANT

DIN
338



MUST HAVE

DIN
340

**HSS M2 DUGA SPIRALNA POTPUNO
BRUŠENA BURGIJA, DIN 340**

ŠIFRA	PREČNIK	DUŽINA	PAKET	€/KOM.
74045	3,0mm	100mm	10	1,00
74046	3,5mm	112mm	10	1,10
74047	4,0mm	119mm	10	1,20
74048	4,5mm	126mm	10	1,60
74049	5,0mm	132mm	10	1,90
74050	5,5mm	138mm	10	2,40
74051	6,0mm	139mm	10	2,70
15686	6,5mm	146mm	5	3,20
74052	7,0mm	156mm	5	4,00
74053	8,0mm	165mm	5	5,30
74054	9,0mm	175mm	5	6,20
74055	10,0mm	184mm	5	8,60
74056	11,0mm	195mm	5	10,00
74057	12,0mm	208mm	5	14,00



MADE IN
GERMANY



DIN
1897

**KOBALTNA HSS+CO5%
STANDARDNA BURGIJA,
KRATKA, DIN 1897**

ŠIFRA	PREČNIK	DUŽINA	PAKET	€/KOM.
74066	2,5mm	43mm	10	0,90
74067	3,0mm	46mm	10	1,10
74068	3,2mm	49mm	10	1,30
74069	3,5mm	52mm	10	1,40
74070	4,0mm	55mm	10	1,50
74071	4,2mm	55mm	10	1,60
74072	4,5mm	58mm	10	1,60
74073	5,0mm	62mm	10	1,90
74074	5,2mm	62mm	10	2,00
74075	5,5mm	66mm	10	2,00
74076	6,0mm	66mm	10	2,20



- Idealna za bušenje sa zakovicama



*KOLIČINA PRI VIŠESTRUKOJ PORUČBINI

MUST
HAVE



BURGIJA ZA STAKLO

ŠIFRA	PREČNIK	KUTIJA	€ /KOM.
74728	4mm	100	3,00
74729	5mm	100	3,20
74730	6mm	100	3,60
74731	8mm	100	4,60
74732	10mm	100	5,50



*KOLIČINA PRI VIŠESTRUKOJ PORUČBINI

MUST
HAVE



**OLOVKA OBELEŽIVAČ
ZA METALNE PREDMETE**

ŠIFRA	DUŽINA	€ /KOM.
74664	140mm	3,40



NEW



**METALNA KRUNA (TESTERA)
ZA BUŠENJE RUPA HSS M2**

ŠIFRA	PREČNIK	VISINA	KUTIJA	€/KOM.
72328	16mm	19mm	20	8,50
72329	18mm	19mm	20	10,00
72330	20mm	19mm	20	11,00
72331	22mm	19mm	20	11,50
72332	24mm	19mm	20	13,00
72333	25mm	19mm	20	13,50
72334	26mm	19mm	10	14,00
72335	28mm	19mm	10	15,50
72336	30mm	19mm	10	16,00
72337	32mm	19mm	10	17,00
72338	33mm	19mm	10	18,00
72339	35mm	19mm	10	19,50
72340	38mm	19mm	10	20,50
72341	40mm	19mm	10	22,00
72342	45mm	19mm	6	24,50
72343	50mm	19mm	6	27,00
72344	55mm	19mm	4	30,00
72345	60mm	19mm	2	32,00
72346	65mm	19mm	2	40,00
72347	70mm	19mm	3	46,00
72348	75mm	19mm	3	49,00
72349	80mm	19mm	3	51,00
72350	85mm	19mm	3	55,00
72351	90mm	19mm	3	61,00
72352	100mm	19mm	2	67,00

- Konstruisan od čelika velike brzine (HSS M2) sa naoštrenom ivicom za sečenje sa strane i visokim performansama
- Efektivna dubina sečenja: 11mm
- Prečnik šenka: 10mm
- Idealan za bušenje rupa od nerđajućeg čelika, aluminijuma, mesinga, livenog gvožđa, sve vrste drveta, PVC
- Uključen: centrirajući pilot adapter, hss pilot burgija i alen ključ

NEW MUST HAVE



**KRUNA (TESTERA)
ZA BUŠENJE RUPA, KARBIDNA,
ZA INOKS I METAL**

ŠIFRA	PREČNIK	VISINA	KUTIJA	€/KOM.
72353	16mm	12mm	15	21,00
72354	17mm	12mm	10	21,00
72355	18mm	12mm	15	21,00
72356	19mm	12mm	10	21,00
72357	20mm	12mm	15	21,00
72358	21mm	12mm	10	24,00
72359	22mm	12mm	15	24,00
72360	24mm	12mm	10	24,00
72361	25mm	12mm	10	24,00
72362	26mm	12mm	10	25,00
72363	28mm	12mm	10	25,00
72364	30mm	12mm	10	25,00
72365	32mm	12mm	10	29,00
72366	33mm	12mm	12	29,00
72367	34mm	12mm	10	29,00
72368	35mm	12mm	5	29,00
72369	38mm	12mm	5	31,00
72370	40mm	12mm	5	31,00
72371	43mm	12mm	5	34,00
72372	45mm	12mm	1	34,00
72373	50mm	12mm	1	36,00
72374	55mm	12mm	1	40,00
72375	60mm	12mm	1	43,00

- Sa karbidnim zubima za odličnu trajnost i glatku posekotinu od nerđajućeg čelika i drugih tvrdih metala
- Efektivna dubina sečenja: 4,5mm
- Prečnik šenka: 10mm
- Idealan za bušenje rupa od nerđajućeg čelika, aluminijuma, mesinga, livenog gvožđa, plastike, stakla
- Uključen: centrirajući pilot adapter, hss pilot burgija i alen ključ

*KOLIČINA PRI VIŠESTRUKOJ PORUČBINI

NEW MUST HAVE

**PRODUŽENA KRUNA (TESTERA)
 ZA BUŠENJE RUPA, KARBIDNA,
 ZA INOKS I METAL**

ŠIFRA	PREČNIK	VISINA	KUTIJA	€/KOM.
72376	16mm	25mm	12	34,00
72377	18mm	25mm	12	34,00
72378	19mm	25mm	12	34,00
72379	20mm	25mm	12	34,00
72380	22mm	25mm	12	39,00
72381	25mm	25mm	6	39,00
72382	28mm	25mm	6	42,00
72383	30mm	25mm	6	42,00
72384	32mm	25mm	6	46,00
72385	35mm	25mm	4	46,00
72386	38mm	25mm	4	54,00
72387	40mm	25mm	4	54,00
72388	45mm	25mm	1	61,00
72389	50mm	25mm	1	62,00
72390	55mm	25mm	1	67,00
72391	60mm	25mm	1	82,00

- Sa karbidnim zubima za odličnu trajnost i glatku posekotinu od nerđajućeg čelika i drugih tvrdih metala
- Efikasna dubina sečenja: 13 - 25mm
- Prečnik šenka: 10mm
- Idealan za bušenje rupa od nerđajućeg čelika, aluminijumu, mesingu, livenom gvožđu, plastici, staklu, tubularnim proizvodima
- Uključen: centrirajući pilot adapter, hss pilot burgija i alen ključ

NEW MUST HAVE

HSS PILOT BURGIIJA

ŠIFRA	PREČNIK	DUŽINA	ODGOVARA	KUTIJA	€/KOM.
72396	6mm	48mm	72353 - 72375	10	4,50
72397	6mm	76mm	72376 - 72391	10	5,00

NEW

**HSS M2 PILOT BURGIIJA,
 ZA TESTERE ZA RUPE U METALU**

ŠIFRA	PREČNIK	DUŽINA	ODGOVARA	KUTIJA	€/KOM.
72395	6mm	45mm	72328 - 72352	10	2,00

NEW MUST HAVE

SAMOCENTRIRAJUĆA PILOT BURGIIJA

ŠIFRA	PREČNIK	DUŽINA	ODGOVARA	€/KOM.
72398	8,5mm	20mm	72353 - 72375	0,80
72399	8,5mm	35mm	72376 - 72391	0,80

*KOLIČINA PRI VIŠESTRUKOJ PORUČBINI

BENMAN[®]
 PROFESSIONAL TOOLS

BEST SELLER **MUST HAVE**



COBALT 8%

- Prečnici krune za bušenje rupa po upotrebi:
Opšta namena: 16-17-22-29-35-51-54-127,
Održavanje: 16-21-25-40-51,
Električar: 22-29-35-44-51-65,
Električar održavanja: 19-22-29-35-38-44-51-57-65,
Čelična konstrukcija: 21-35-38-54-60,
Provodnik toplote: 19-29-35-40-44-51,
Provodnik: 19-22-29-38-44-57,
Objekat održavanja: 22-29-35-44-51



**KRUNA (TESTERA) ZA BUŠENJE RUPA,
2 MATERIJALA, KOBALT 8%**

ŠIFRA	PREČNIK	KOMBINIRATI S	KUTIJA	€/KOM.
74200	16mm	5/8"	74240	6 5,20
74201	17mm	11/16"	74240	6 5,60
74202	19mm	3/4"	74240	25 5,80
74203	21mm	13/16"	74240	25 6,10
74204	22mm	7/8"	74240	25 6,30
74205	25mm	1"	74240	25 6,70
74206	29mm	1 1/8"	74240	6 7,70
74207	30mm	1 3/16"	74240	25 7,80
74208	33mm	1 5/16"	74242	25 8,00
74209	35mm	1 3/8"	74242	25 8,20
74211	38mm	1 1/2"	74242	25 8,50
74212	40mm	1 9/16"	74242	16 8,70
74213	44mm	1 3/4"	74242	25 9,20
74214	46mm	1 13/16"	74242	6 9,40
74216	51mm	2"	74242	16 10,10
74217	54mm	2 1/8"	74242	6 10,80
74218	57mm	2 1/4"	74242	6 11,20
74220	60mm	2 3/8"	74242	6 11,70
74221	64mm	2 1/2"	74242	6 12,50
74222	67mm	2 5/8"	74242	6 13,30
74223	70mm	2 3/4"	74242	6 14,00
74224	73mm	2 7/8"	74242	6 14,70
74225	76mm	3"	74242	6 15,30
74227	83mm	3 1/4"	74242	6 16,50
74228	86mm	3 3/8"	74242	6 16,90
72119	92mm	3 5/8"	74242	36 17,00
72120	95mm	3 3/4"	74242	36 18,00
74229	102mm	4"	74242	6 20,40
74230	108mm	4 1/4"	74 242	24 21,10
74231	111mm	4 3/8"	74 242	24 22,20
74232	114mm	4 1/2"	74242	6 23,30
74233	121mm	4 3/4"	74242	20 24,20
74234	127mm	5"	74242	20 25,40
72121	140mm	5 1/2"	74242	12 27,00
72122	152mm	6"	74242	12 28,00
72123	160mm	6 5/16"	74242	12 33,00
72124	168mm	6 5/8"	74242	12 36,00
72126	178mm	7"	74242	10 39,00
72127	210mm	8 1/4"	74242	10 49,00

MUST HAVE

HSS



CENTRIRAJUĆI PILOT ADAPTER

ŠIFRA	VELIČINA	KUTIJA	€/KOM.
74240	14 - 30mm	6	5,30
74242	32 - 210mm	6	10,30

MUST HAVE

HSS



HSS PILOT BURGIIJA

ŠIFRA	PREČNIK	KUTIJA	€/KOM.
74244	6,35mm	25	3,00

*KOLIČINA PRI VIŠESTRUKOJ PORUČBINI

MOKRI
REZ



DIJAMANTSKA BURGIIJA

ŠIFRA	PREČNIK	KUTIJA	€/KOM.
73988	6mm	6	9,50
73989	8mm	6	10,00
73990	10mm	6	11,00
73991	12mm	6	12,00
73992	14mm	6	13,00



MUST
HAVE

MOKRI REZ
& SUVI REZ



DIJAMANTSKI BUŠAČ RUPA

ŠIFRA	PREČNIK	KUTIJA	€/KOM.
73994	22mm	6	20,00
73995	35mm	6	27,00
73996	40mm	6	31,00
73997	45mm	6	34,00



*KOLIČINA PRI VIŠESTRUKOJ PORUĐBINI

MUST HAVE

HSS



ROTACIONA TURPIJA
SA KONUSNIM VRHOM

ŠIFRA	GLAVOM Ø	PREČNIK	€/KOM.
74105	5-25mm	8mm	11,00



MUST HAVE



ROTACIONA TURPIJA
SA KONUSNIM VRHOM

ŠIFRA	GLAVOM Ø	PREČNIK	€/KOM.
74101	6-13mm	6mm	3,40



MUST HAVE



ROTACIONA TURPIJA
SA CILINDRIČNIM VRHOM

ŠIFRA	GLAVOM Ø	PREČNIK	€/KOM.
74100	13mm	6mm	3,40



MUST HAVE



ROTACIONA TURPIJA
SA POLUOKRUGLIM VRHOM

ŠIFRA	GLAVOM Ø	PREČNIK	€/KOM.
74103	12mm	6mm	3,40



*KOLIČINA PRI VIŠESTRUKOJ PORUČBINI

MUST
HAVE



**KRUŽNA ROTACIONA TURPIJA
ZA DRVO**

ŠIFRA	GLAVOM Ø	PREČNIK	€/KOM.
74106	16mm	6mm	3,40



MUST
HAVE



**KONUSNA ROTACIONA TURPIJA
ZA DRVO**

ŠIFRA	GLAVOM Ø	PREČNIK	€/KOM.
74107	6-15mm	6mm	3,40



MUST
HAVE



**SFERNA ROTACIONA TURPIJA
ZA DRVO**

ŠIFRA	GLAVOM Ø	PREČNIK	€/KOM.
74108	15mm	6mm	3,40



MUST
HAVE



**POLUSFERNA ROTACIONA TURPIJA
ZA DRVO**

ŠIFRA	GLAVOM Ø	PREČNIK	€/KOM.
74109	16mm	6mm	3,40



*KOLIČINA PRI VIŠESTRUKOJ PORUČBINI



**HSS TURPIJA-TESTERA
I BURGIJA ZA DRVO**

ŠIFRA	PREČNIK	DUŽINA	€ /KOM.
74044	6mm	93mm	6,30

• Preporučena brzina: 1.000 - 2.000 rpm



TURPIJA ZA ODVIJANJE

ŠIFRA	PREČNIK	€ /KOM.
74104	12mm	7,20



**EKSTRAKTOR
NAVOJA, 5 KOM**

ŠIFRA	SET	€ /SET
74099	5pcs	8,00

• Za vijke M3-M18



**MUST
HAVE**

HSS M2



**HSS STEPENASTA
BURGIJA**

ŠIFRA	GLAVOM Ø	PREČNIK	€ /KOM.
74351	4-30mm	10mm	49,50



*KOLIČINA PRI VIŠESTRUKOJ PORUČBINI

NEW MUST HAVE



**PODESIVI REZAČ
PLAFONSKIH RUPA**

ŠIFRA	KUTIJA	€ /KOM.
72129	6	129,00

- Podesivi rezač rupa prečnika 48-305mm
- Dubina sečenja 5-30mm
- Idealno za sečenje plafona, zidova i podova napravljenih od čipborda, šperploče, gipsa, betonske daske itd



UKLJUČUJE

- 1 rezač sa testerom i brugijom
- 7mm od karbida
- 1 branik
- 2 rezervna rezna lista HSS
- 1 ključ ALLEN 3mm
- 1 ključ ALLEN 4mm
- 1 transportna kutija



Jasan štit od prašine poboljšava vidljivost
prilikom sakupljanja zaostaka

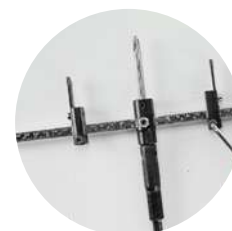

Prečnik sečenja rupe se lako menja
pomeranjem držača sečiva



Podloška za regulaciju dubine
rezanja

NEW



**TUNGSTEN KARBONSKA
REZERVNA SEČIVA**

ŠIFRA	KUTIJA	€ /SET
72131	10	16,50

NEW



HSS REZERVNA SEČIVA

ŠIFRA	KUTIJA	€ /SET
72130	10	10,30

NEW



**TUNGSTEN KARBONSKA
BURGIJA BIT 7mm
ZA REZAČ PLAFONSKIH RUPA**

ŠIFRA	KUTIJA	€ /KOM.
72132	10	10,00

*KOLIČINA PRI VIŠESTRUKOJ PORUČBINI

NEW **MUST HAVE**



**BURGIJA ZA DRVO,
SA HEX PRIHVATOM 1/4"**

ŠIFRA	PREČNIK	UKUPNA DUŽINA	DUŽINA MREŽE	PAKET	KUTIJA	€/PAK.
72112	2mm	69mm	24mm	2	250	1,50
72113	3mm	81mm	33mm	2	250	2,20
72114	4mm	95mm	43mm	2	250	2,60
72115	5mm	106mm	52mm	1	125	1,80
72116	6mm	113mm	57mm	1	125	2,30
72117	8mm	117mm	75mm	1	100	3,70
72118	10mm	133mm	87mm	1	50	5,50



BEST SELLER **MUST HAVE**



BRAD POINT BURGIJA ZA DRVO

ŠIFRA	PREČNIK	DUŽINA	KUTIJA	€/KOM.
74680	3mm	61mm	50	1,00
74681	4mm	75mm	40	1,20
74682	5mm	86mm	40	1,20
74683	6mm	93mm	40	1,30
74684	7mm	109mm	25	1,50
74685	8mm	117mm	25	1,60
74686	9mm	125mm	25	1,80
74687	10mm	133mm	20	1,90
74688	11mm	142mm	20	2,30
74689	12mm	151mm	15	2,50
74690	13mm	151mm	15	2,60
74691	14mm	158mm	15	3,80
74692	15mm	169mm	15	4,30
74693	16mm	180mm	15	4,90
74694	18mm	197mm	10	6,10
74695	20mm	230mm	10	7,20



MUST TRY



**BURGIJA SVRDLO,
SA ČETIRI REZNA VRHA,
SA HEX PRIHVATOM**

ŠIFRA	PREČNIK	KUTIJA	€/KOM.
71742	16mm	10	9,50
71743	18mm	10	10,50
71744	20mm	10	11,00
71745	22mm	10	12,00
71746	25mm	10	14,00
71747	28mm	10	18,00
71748	30mm	10	19,00
71749	32mm	10	20,00

- 2 puta brža i preciznija penetracija

2x
CLEANER

2x
FASTER



MUST HAVE



BURGIJA SVRDLO ZA DRVO

ŠIFRA	PREČNIK	DUŽINA	KUTIJA	€/KOM.
74093	6mm	235mm	25	4,00
74094	6mm	460mm	25	6,40
74699	8mm	235mm	25	4,40
74705	8mm	460mm	25	6,80
74700	10mm	235mm	20	4,80
74706	10mm	460mm	20	7,00
74701	12mm	235mm	20	5,50
74707	12mm	460mm	20	8,50
74702	14mm	235mm	15	6,00
74703	16mm	235mm	15	6,80
74708	16mm	460mm	15	11,50
74095	18mm	235mm	15	7,70
74096	18mm	460mm	15	12,50
74704	20mm	235mm	10	8,50
74709	20mm	460mm	10	13,00



*KOLIČINA PRI VIŠESTRUKOJ PORUČBINI

**BEST
SELLER** **MUST
HAVE**

RAVNA LEPTIR BURGIJA ZA DRVO



ŠIFRA	PREČNIK	DUŽINA	REZERVNI DELOVI	KUTIJA	€/KOM.
74713	8mm	150mm	74665	6	1,90
74714	10mm	150mm	74665	6	2,00
74715	12mm	150mm	74665	6	2,20
74716	14mm	150mm	74665	6	2,20
74717	16mm	150mm	74665	6	2,30
74718	18mm	150mm	74665	6	2,40
74719	20mm	150mm	74665	6	2,50
74720	22mm	150mm	74665	6	2,60
74721	24mm	150mm	74665	6	2,70
74722	25mm	150mm	74665	6	2,70
74723	28mm	150mm	74665	6	3,00
74724	30mm	150mm	74665	6	3,10
74725	32mm	150mm	74665	6	3,30
74726	35mm	150mm	74665	6	3,50
74727	40mm	150mm	74665	6	4,00

**MUST
TRY**



**PRILAGODLJIVA RAVNA LEPTIR
BURGIJA ZA DRVO**

ŠIFRA	PREČNIK	KUTIJA	€/KOM.
74663	15-45mm	150	19,00

NASTAVAK ZA RAVNU BURGiju

ŠIFRA	DUŽINA	POGODAN ZA	KUTIJA	€/KOM.
74665	270mm	74713-74727	20	4,00

**MUST
HAVE**



**STOLARSKA
I VODOINSTALATERSKA
BURGIJA**

ŠIFRA	PREČNIK	DUŽINA	KUTIJA	€/KOM.
74646	8mm	400mm	15	7,00
74650	8mm	600mm	15	7,50
74647	10mm	400mm	10	7,50
74651	10mm	600mm	10	9,50
74648	12mm	400mm	10	9,50
74652	12mm	600mm	10	10,50
74649	14mm	400mm	10	11,00
74653	14mm	600mm	10	12,00

**MUST
TRY**



**10x
MORE
DURABLE**



BURGIJA ZA BUŠENJE ŠARKI

ŠIFRA	PREČNIK	KUTIJA	€/KOM.
74711	30mm	100	16,60
74712	35mm	100	16,60

• 10x izdržljivije od običnih burgija

**BEST
SELLER** **MUST
HAVE**



BURGIJA ZA BUŠENJE ŠARKI

ŠIFRA	PREČNIK	KUTIJA	€/KOM.
74356	26mm	20	6,00
74357	30mm	20	6,20
74358	35mm	20	6,40

*KOLIČINA PRI VIŠESTRUKOJ PORUČBINI

MUST HAVE

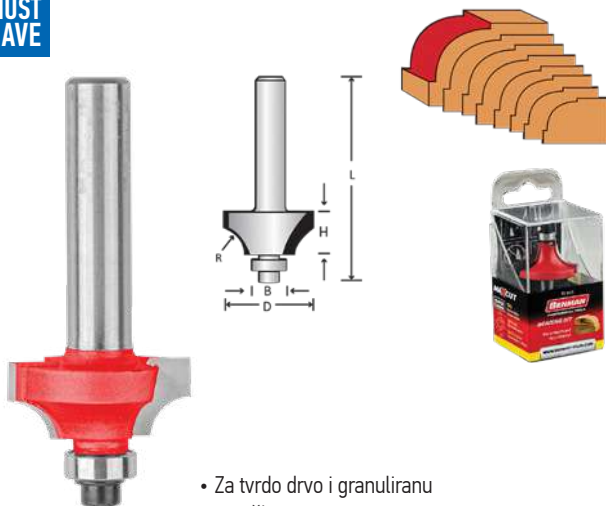

• Za tvrdo drvo i granuliranu površinu

ZRNASTA BURGIIJA SA VRHOM OD 8mm

ŠIFRA	D	B	R	L	H	KUTIJA	€/KOM.
71940	18,7mm	9,5mm	3mm	53mm	12,7mm	10	12,50
71941	20,7mm	9,5mm	4mm	53mm	7,5mm	10	13,50
71942	24,7mm	9,5mm	6mm	53mm	10,5mm	10	16,50
71943	28,7mm	9,5mm	8mm	53mm	12,2mm	10	19,00
71944	32,7mm	9,5mm	10mm	57mm	15,5mm	10	21,00
71945	36,7mm	9,5mm	12mm	60mm	18,5mm	10	25,00
71946	42,7mm	9,5mm	15mm	66mm	21,5mm	10	29,00

MUST HAVE



• Za tvrdo drvo i granulirane ploče

RAVNE BURGIIJE SA VRHOM OD 8mm

ŠIFRA	D	L	H	KUTIJA	€/KOM.
71947	9,5mm	68mm	25,4mm	10	8,80
71948	12,7mm	68mm	25,4mm	10	9,50

MUST HAVE

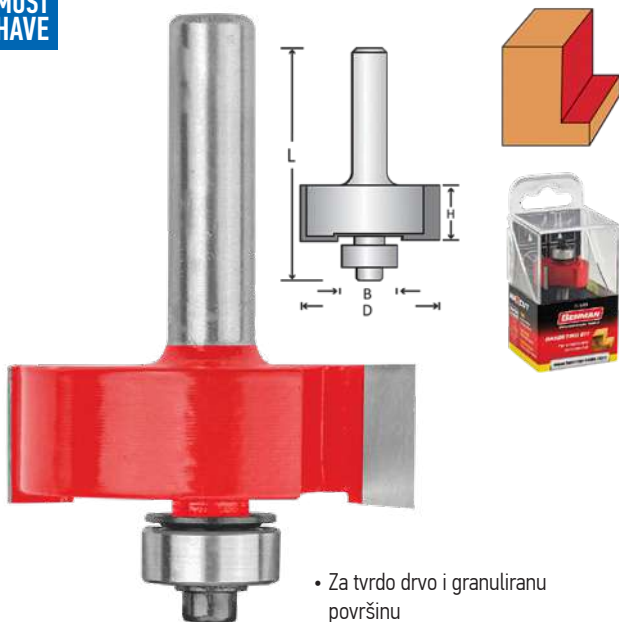

• Za tvrdo drvo i granuliranu površinu

UŽLEBLJENA BURGIIJA SA VRHOM OD 8mm

ŠIFRA	D	B	L	H	KUTIJA	€/KOM.
71949	31,8mm	12,7mm	54mm	12,7mm	10	19,00

MUST HAVE



• Za meko i tvrdo drvo i granuliranu površinu

DUGAČKE PRAVE BURGIIJE, DVA TALASASTA VRHA OD 8mm

ŠIFRA	D	L	H	KUTIJA	€/KOM.
71956	8mm	56mm	25,4mm	10	6,30
71957	10mm	56mm	25,4mm	10	6,50
71958	12mm	61mm	30,0mm	10	6,80

*KOLIČINA PRI VIŠESTRUKOJ PORUČBINI

MUST HAVE

• Za tvrdo drvo

GLODALO ZA ISKOŠAVANJE IVICA 8mm

ŠIFRA	D	B	L	H	A	KUTIJA	€/KOM.
71955	35,5mm	12,7mm	56mm	16,5mm	45°	10	20,00

MUST HAVE

• Za tvrdo drvo, ploče, sintetičke površine, granulirani materijal

PRAVE BURGIJE, DVA TALASASTA VRHA OD 8mm

PRAVE BURGIJE, DVA TALASASTA VRHA OD 8mm

ŠIFRA	D	L	H	KUTIJA	€/KOM.
71926	6mm	51mm	20mm	10	9,50
71927	7mm	51mm	20mm	10	9,50
71928	8mm	51mm	20mm	10	9,50
71929	9mm	51mm	20mm	10	9,80
71930	10mm	51mm	20mm	10	9,80
71931	11mm	51mm	20mm	10	10,80
71932	12mm	51mm	20mm	10	10,80
71933	13mm	51mm	20mm	10	10,80
71934	15mm	51mm	20mm	10	12,00
71935	16mm	51mm	20mm	10	12,00
71936	18mm	51mm	20mm	10	13,50
71937	19mm	51mm	20mm	10	14,50
71938	22mm	51mm	20mm	10	15,50
71939	25mm	51mm	20mm	10	17,00

MUST HAVE

• Za tvrdo drvo i granuliranu površinu

ČVRSTE KARBID PRAVE BURGIJE, SA TALASASTIM VRHOM OD 8mm

ŠIFRA	D	L	H	KUTIJA	€/KOM.
71950	3mm	51,0mm	8,0mm	10	10,50
71951	4mm	51,0mm	8,0mm	10	11,50
71952	5mm	53,7mm	12,7mm	10	15,00

MUST HAVE

• Za tvrdo drvo

BURGIJA U OBLIKU LASTINOŠ REPA SA VRHOM OD 8mm

ŠIFRA	D	L	H	A	KUTIJA	€/KOM.
71925	12,7mm	55mm	12,7mm	14°	10	9,00

MUST HAVE

• Za tvrdo drvo

BURGIJA U VIDU V-ŽLEBA SA VRHOM OD 8mm

ŠIFRA	D	L	H	A	KUTIJA	€/KOM.
71953	12,7mm	45mm	16mm	60°	10	9,20
71954	16,0mm	45mm	16mm	90°	10	10,00

*KOLIČINA PRI VIŠESTRUKOJ PORUDŽBINI

BEST SELLER **MUST HAVE**



**ZIDARSKA BURGIJA
ZA KAMEN**

ŠIFRA	PREČNIK	DUŽINA	KUTIJA	€/KOM.
74592	4mm	75mm	75	0,90
74593	5mm	85mm	75	0,90
74594	6mm	100mm	50	1,10
74595	7mm	110mm	50	1,20
74596	8mm	115mm	50	1,40
74597	9mm	125mm	40	1,60
74598	10mm	125mm	40	1,80
74599	12mm	140mm	30	2,40
74600	14mm	150mm	25	2,50
74601	16mm	150mm	25	3,30
74602	18mm	160mm	25	4,50
74603	20mm	160mm	25	6,50



BEST SELLER **MUST HAVE** **MUST TRY**



**ZIDARSKA BURGIJA
ZA SUPER BETON**

ŠIFRA	PREČNIK	DUŽINA	€/KOM.
74890	4,0mm	75mm	1,20
74891	5,0mm	85mm	1,30
74925	5,5mm	85mm	1,40
74892	6,0mm	100mm	1,40
74893	6,0mm	150mm	2,00
74894	6,0mm	200mm	2,30
74895	6,0mm	300mm	4,30
74896	6,0mm	400mm	8,70
74897	7,0mm	100mm	1,60
74898	8,0mm	120mm	2,10
74899	8,0mm	150mm	2,40
74900	8,0mm	200mm	2,70
74901	8,0mm	300mm	4,30
74902	8,0mm	400mm	8,70
74903	9,0mm	120mm	2,20
74904	10,0mm	120mm	2,50
74905	10,0mm	150mm	2,80
74906	10,0mm	200mm	3,30
74907	10,0mm	300mm	4,80
74908	10,0mm	400mm	8,90
74909	12,0mm	150mm	3,30
74910	12,0mm	200mm	4,40
74911	12,0mm	300mm	6,40
74912	12,0mm	400mm	8,90
74913	14,0mm	150mm	5,20
74914	14,0mm	200mm	6,60
74915	14,0mm	300mm	8,10
74916	14,0mm	400mm	10,40
74917	16,0mm	150mm	6,40
74918	16,0mm	200mm	8,00
74919	16,0mm	300mm	9,40
74920	16,0mm	400mm	11,50
74921	18,0mm	160mm	8,70
74924	18,0mm	400mm	14,50
74923	20,0mm	160mm	10,00



Četverostruka spirala
za brže uklanjanje



Posebno dizajniran
karbidni vrh za veću
brzinu i izdržljivost



Trogaoni prihvata za
povećanu stabilnost u
glavi bušilice

*KOLIČINA PRI VIŠESTRUKOJ PORUČBINI

**BEST
SELLER** **MUST
HAVE**

**SUPER
GRANIT**



**ZIDARSKA BURGIJA
ZA SUPER GRANIT**

ŠIFRA	PREČNIK	DUŽINA	KUTIJA	€/KOM.
74383	4,0mm	80mm	200	1,40
74384	5,0mm	90mm	200	1,80
74465	5,5mm	95mm	200	2,20
74385	6,0mm	100mm	200	2,30
74386	7,0mm	110mm	100	2,60
74387	8,0mm	120mm	100	2,80
74389	10,0mm	140mm	50	4,20
74390	12,0mm	160mm	50	5,30
74391	14,0mm	200mm	25	7,30

• Udarne ili bez udaranja



Posebno dizajniran profil za izvrsno bušenje



Posebno dizajniran karbidni vrh za veću brzinu, otpornost na habanje i duži vek trajanja

**BEST
SELLER** **NICE
TO HAVE**



**UNIKRAFT VIŠENAMENSKA
BURGIJA**

ŠIFRA	PREČNIK	DUŽINA	KUTIJA	€/KOM.
74629	4,0mm	80mm	200	1,50
74630	5,0mm	90mm	250	1,90
74466	5,5mm	95mm	200	2,40
74631	6,0mm	100mm	200	2,40
74632	8,0mm	120mm	100	3,00
74633	10,0mm	140mm	50	4,50
74634	12,0mm	160mm	50	5,60
74635	14,0mm	200mm	50	7,70
74636	16,0mm	150mm	30	13,20

• Bez udaranja



Posebno dizajnirana spirala za brže uklanjanje materijala

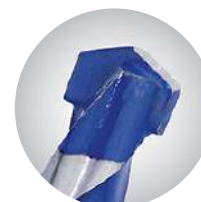

Posebno dizajniran karbidni vrh sa dodatno naoštrenim ivicama za struganje, radi preciznosti bušenja

*KOLIČINA PRI VIŠESTRUKOJ PORUČBINI

**BEST
SELLER**



ZIDARSKA BURGIIJA, 5 KOM

ŠIFRA	SET	KUTIJA	€/SET
74671	5pcs	65	5,50

UKLJUČUJE
4/ 5/ 6/ 8/ 10mm



**ZIDARSKA BURGIIJA
ZA GRANIT, 4 KOM**

ŠIFRA	SET	KUTIJA	€/SET
74673	4pcs	15	9,00

UKLJUČUJE
4/ 5/ 6/ 8mm



**BEST
SELLER**



**HSS SPIRALNA BURGIIJA
SA KOVANOM GLAVOM +
ZIDARSKA BURGIIJA
ZA KAMEN, 9 KOM**

ŠIFRA	SET	KUTIJA	€/SET
74675	9pcs	16	8,00

UKLJUČUJE
HSS: 3/ 4/ 5/ 6/ 8mm
STONE: 4/ 5/ 6/ 8mm



**BEST
SELLER**



**VIŠENAMENSKA
BURGIJA, 5 KOM**

ŠIFRA	SET	KUTIJA	€/SET
71149	5pcs	12	14,00

UKLJUČUJE
4/ 5/ 6/ 8/ 10mm

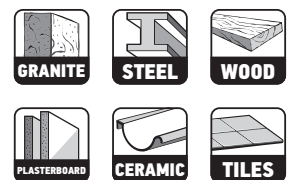

**BEST
SELLER**



**HSS BURGIIJA, DIN 338,
19 KOM**

ŠIFRA	KUTIJA	€/SET
74676	30	21,00

UKLJUČUJE
1/ 1,5/ 2/ 2,5/ 3/ 3,5/ 4/
4,5/ 5/ 5,5/ 6/ 6,5/ 7/ 7,5/
8/ 8,5/ 9/ 9,5/ 10mm



**BEST
SELLER**



**KOBALTNA HSS+CO5%
BURGIJA, DIN 338, 19 KOM**

ŠIFRA	KUTIJA	€/SET
74677	15	45,00

UKLJUČUJE
1/ 1,5/ 2/ 2,5/ 3/ 3,5/ 4/
4,5/ 5/ 5,5/ 6/ 6,5/ 7/ 7,5/
8/ 8,5/ 9/ 9,5/ 10mm



*KOLIČINA PRI VIŠESTRUKOJ PORUČBINI

**BEST
SELLER** **MUST
HAVE**

2 PLUS

2PLUS UDARNA BURGIJA SDS PLUS



- +25% brže
- +50% izdržljivije

ŠIFRA	PREČNIK	DUŽINA	KUTIJA	€/KOM.
74400	5,0mm	110mm	50	2,70
74401	5,0mm	160mm	50	3,20
74784	5,0mm	210mm	70	4,40
74785	5,0mm	310mm	70	10,60
74786	5,5mm	160mm	50	3,40
74787	5,5mm	210mm	70	5,60
74788	5,5mm	310mm	70	10,50
74402	6,0mm	110mm	300	2,60
74403	6,0mm	160mm	250	2,80
74404	6,0mm	210mm	200	4,00
74405	6,0mm	260mm	50	5,20
74406	6,0mm	310mm	70	9,70
74407	6,0mm	460mm	30	12,40
74408	6,5mm	160mm	50	4,00
74409	6,5mm	210mm	70	5,40
74777	6,5mm	310mm	70	10,50
74410	7,0mm	160mm	50	3,60
74411	7,0mm	210mm	70	4,90
74412	8,0mm	160mm	200	3,30
74413	8,0mm	210mm	150	4,00
74414	8,0mm	260mm	50	5,00
74415	8,0mm	310mm	70	6,90
74416	8,0mm	460mm	30	11,80
74417	9,0mm	160mm	50	4,60
74418	9,0mm	210mm	50	5,20
74419	10,0mm	160mm	150	3,80
74420	10,0mm	210mm	100	4,80
74421	10,0mm	260mm	50	5,90
74422	10,0mm	310mm	70	7,20
74423	10,0mm	450mm	30	12,20
74424	10,0mm	600mm	30	15,70
74789	11,0mm	210mm	50	7,60
74790	11,0mm	310mm	70	10,00
74426	12,0mm	160mm	100	4,90
74427	12,0mm	210mm	100	5,70
74428	12,0mm	260mm	80	7,00
74429	12,0mm	310mm	70	8,70
74430	12,0mm	450mm	30	13,50
74431	12,0mm	600mm	30	18,90
74432	12,0mm	1.000mm	25	40,00
74433	14,0mm	160mm	100	6,00
74434	14,0mm	210mm	100	7,30
74435	14,0mm	260mm	50	9,40
74436	14,0mm	310mm	60	10,70
74437	14,0mm	450mm	30	14,60
74438	14,0mm	600mm	20	21,70
74439	14,0mm	1.000mm	25	44,70
74440	16,0mm	210mm	40	10,00
74441	16,0mm	260mm	50	11,30
74442	16,0mm	310mm	60	13,30
74443	16,0mm	450mm	20	18,60
74444	16,0mm	600mm	30	23,80

ŠIFRA	PREČNIK	DUŽINA	KUTIJA	€/KOM.
74445	16,0mm	1.000mm	20	47,50
74446	18,0mm	210mm	25	10,00
74447	18,0mm	300mm	25	13,00
74448	18,0mm	450mm	15	18,00
74449	18,0mm	600mm	15	22,00
74450	18,0mm	1.000mm	8	49,00
74451	20,0mm	300mm	25	15,00
74452	20,0mm	450mm	15	19,00
74453	20,0mm	600mm	15	25,00
74454	20,0mm	1.000mm	8	56,00
74455	22,0mm	300mm	25	17,00
74456	22,0mm	450mm	15	22,00
74457	22,0mm	600mm	15	30,00
74458	22,0mm	1.000mm	8	61,00
74459	24,0mm	450mm	15	24,00
74460	25,0mm	450mm	15	27,00
74461	26,0mm	450mm	10	29,00
74463	30,0mm	450mm	10	54,00



MADE IN
GERMANY



+50%
MORE
DURABLE



+25%
FASTER

MUST TRY

4PLUS

**4PLUS UDARNA BURGIJA
SDS PLUS**

ŠIFRA	PREČNIK	DUŽINA	KUTIJA	€/KOM.
71750	5,0mm	115mm	300	4,00
71751	5,0mm	160mm	250	4,30
71752	5,5mm	110mm	300	4,30
71753	5,5mm	160mm	250	4,80
71754	6,0mm	110mm	300	4,00
71755	6,0mm	160mm	250	4,30
71756	6,0mm	210mm	200	5,70
71757	6,0mm	260mm	50	7,20
71758	6,0mm	310mm	150	10,00
71759	6,5mm	160mm	50	5,80
71760	6,5mm	210mm	150	7,90
71761	6,5mm	260mm	150	10,40
71762	7,0mm	160mm	150	5,90
71763	8,0mm	110mm	250	4,70
71764	8,0mm	160mm	200	5,00
71765	8,0mm	210mm	150	5,80
71766	8,0mm	260mm	150	7,20
71767	8,0mm	310mm	100	9,70
71768	10,0mm	160mm	150	5,50
71769	10,0mm	210mm	100	6,40
71770	10,0mm	260mm	50	7,60
71771	10,0mm	310mm	100	9,40
71772	10,0mm	450mm	60	16,70
71773	12,0mm	160mm	100	7,20
71774	12,0mm	210mm	100	8,30
71775	12,0mm	260mm	80	9,60
71776	12,0mm	310mm	70	12,40
71777	12,0mm	450mm	50	18,70
71778	14,0mm	160mm	50	9,30
71779	14,0mm	210mm	100	12,50
71780	14,0mm	260mm	80	14,50
71781	14,0mm	310mm	60	16,50
71782	14,0mm	450mm	40	19,80
71783	16,0mm	210mm	80	17,20
71784	16,0mm	260mm	60	19,30
71785	16,0mm	310mm	60	21,60



**+70%
MORE
DURABLE**



Sa 4 ivice

• +70% veća izdržljivost
u armiranom betonu
sa spojnim burgijama

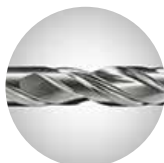

Dvostruka vijugavost



BEST SELLER MUST HAVE

**4x4
TURBO S**

**4X4 TURBO S UDARNA BURGIJA
SDS PLUS**

ŠIFRA	PREČNIK	DUŽINA	KUTIJA	€/KOM.
74750	5,0mm	115mm	50	5,40
74751	5,0mm	165mm	50	5,80
74752	6,0mm	115mm	300	5,30
74753	6,0mm	165mm	250	5,60
74754	6,0mm	215mm	70	7,00
74755	6,0mm	265mm	50	8,80
74756	6,0mm	315mm	50	12,90
74757	6,5mm	165mm	50	7,40
74781	6,5mm	215mm	70	9,40
74758	7,0mm	165mm	50	7,10
74759	8,0mm	165mm	200	6,50
74760	8,0mm	215mm	70	7,30
74761	8,0mm	265mm	50	8,60
74762	8,0mm	315mm	50	12,40
74782	8,0mm	465mm	30	20,80
74763	10,0mm	165mm	150	7,30
74764	10,0mm	215mm	50	8,40
74765	10,0mm	265mm	20	9,70
74766	10,0mm	315mm	30	12,10
74767	10,0mm	455mm	30	21,30
74783	10,0mm	600mm	30	29,00
74768	12,0mm	160mm	100	8,70
74769	12,0mm	210mm	50	9,90
74770	12,0mm	260mm	70	11,70
74771	12,0mm	310mm	70	16,50
74772	12,0mm	450mm	30	22,70
74773	14,0mm	160mm	50	11,70
74774	14,0mm	210mm	50	15,40
74775	14,0mm	310mm	60	18,60
74776	14,0mm	450mm	30	24,20
74778	16,0mm	210mm	40	19,00
74779	16,0mm	310mm	60	24,00
74780	16,0mm	450mm	20	28,40



**+50%
FASTER
EXTRACTION**

**2x
MORE
DURABLE**



Sa 4 ivice

• +100% veća izdržljivost
u armiranom betonu
sa spojnim burgijama
• +50% brže izvlačenje
od 3-4-ivične
SDS PLUS burgije



Četverostruka vijugavost



*KOLIČINA PRI VIŠESTRUKOJ PORUČBINI

**BEST
SELLER** **MUST
HAVE**

TURBO 4S

**TURBO 4S UDARNA BURGIJA
SDS MAX**



ŠIFRA	HEAD	PREČNIK	DUŽINA	KUTIJA	€ /KOM.
74800	2 IVICE	12mm	340mm	25	21,00
74801	2 IVICE	12mm	550mm	18	28,00
74802	2 IVICE	14mm	340mm	25	22,00
74803	2 IVICE	14mm	550mm	25	29,00
74804	4 IVICE	16mm	340mm	25	36,00
74805	4 IVICE	16mm	540mm	18	45,00
74806	4 IVICE	16mm	940mm	10	64,00
74807	4 IVICE	18mm	340mm	25	39,00
74808	4 IVICE	18mm	540mm	18	46,00
74809	4 IVICE	18mm	920mm	10	66,00
74845	4 IVICE	20mm	340mm	25	40,00
74810	4 IVICE	20mm	520mm	18	45,00
74811	4 IVICE	20mm	920mm	10	66,00
74846	4 IVICE	22mm	340mm	25	43,00
74812	4 IVICE	22mm	520mm	18	50,00
74813	4 IVICE	22mm	920mm	10	69,00
74847	4 IVICE	24mm	340mm	15	48,00
74814	4 IVICE	24mm	520mm	10	55,00
74848	4 IVICE	25mm	340mm	15	49,00
74815	4 IVICE	25mm	520mm	10	55,00
74816	4 IVICE	25mm	920mm	8	79,00
74817	4 IVICE	26mm	520mm	8	59,00
74818	4 IVICE	28mm	570mm	12	66,00
74819	4 IVICE	28mm	920mm	5	89,00
74820	4 IVICE	30mm	570mm	12	71,00
74821	4 IVICE	32mm	570mm	8	80,00
74822	4 IVICE	32mm	920mm	5	117,00
74823	4 IVICE	35mm	570mm	8	123,00
74825	4 IVICE	37mm	570mm	8	115,00
74826	4 IVICE	38mm	570mm	8	115,00
74827	4 IVICE	40mm	570mm	8	117,00
74828	4 IVICE	40mm	920mm	2	150,00
74829	4 IVICE	45mm	570mm	8	196,00
74830	4 IVICE	52mm	570mm	4	202,00

- +30% brže izvlačenje
- +30% veća izdržljivost



Sa 4 ivice



Četvorostruka vijugavost

+30%
FASTER
EXTRACTION

+30%
MORE
DURABLE



*KOLIČINA PRI VIŠESTRUKOJ PORUČBINI

NEW **MUST HAVE**



Glava bit bušilice:
Zamenljivo i čvrsto telo
Centralni rezač sa 2 oštrice
Asimetrični raspored karbidnih zuba
Oštra geometrija zuba

**KRUNASTA GLAVA
ZA ISECANJE JEZGARA SDS PLUS**

ŠIFRA	PREČNIK	UKUPNA DUŽINA	KUTIJA	€ /KOM.
72258	30mm	50mm	15	50,00
72259	35mm	50mm	15	56,00
72260	40mm	50mm	10	58,00
72261	45mm	50mm	10	59,00
72262	50mm	50mm	10	61,00
72263	65mm	50mm	5	67,00
72264	68mm	50mm	7	68,00
72265	80mm	50mm	7	73,00
72266	82mm	50mm	7	74,00
72267	90mm	50mm	7	88,00
72268	100mm	50mm	7	96,00

Sklopljeni set iz 3
dela

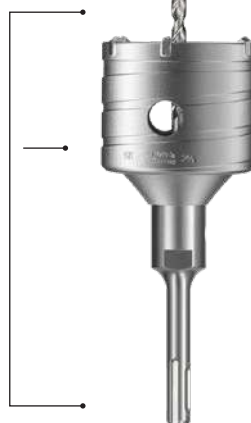

Telo:
Telo jezgra sa spoljašnjom spiralom
Asimetrični raspored rupa
Navoj M16



Kraj za umetanje:
SDS-PLUS, šestougaoni



- Primena: cigla, zidovi
- Precizno izbušene rupe
- Veoma glatko bušenje zahvaljujući asimetričnom rasporedu zuba
- Smanjeno trenje i poboljšano uklanjanje prašine iz bušenja
- Specijalna lagana konstrukcija za bolje rukovanje
- Zamenjivi delovi

NEW **MUST HAVE**



**SDS PLUS ADAPTER
ZA UMETANJE**

ŠIFRA	UKUPNA DUŽINA	KUTIJA	€ /KOM.
72269	105mm	14	22,00
72270	220mm	10	29,00
72271	370mm	10	38,00



- Alen ključ uključen

NEW



**ŠESTOUGAONI ADAPTER
ZA UMETANJE**

ŠIFRA	UKUPNA DUŽINA	KUTIJA	€ /KOM.
72272	90mm	14	23,00
72273	220mm	20	31,00
72274	370mm	10	39,00



- Alen ključ uključen

NEW **MUST HAVE**



**SDS PLUS BURGIIJA
SA CENTRIRAJUĆIM VRHOM**

ŠIFRA	PREČNIK	UKUPNA DUŽINA	KUTIJA	€ /KOM.
72275	8mm	120mm	50	5,10



*KOLIČINA PRI VIŠESTRUKOJ PORUČBINI

NEW



Glava bit bušilice:
Zamenljivo i čvrsto telo
Centralni rezač sa 2 oštrice
Asimetrični raspored karbidnih zuba
Kombinacija ravnih i nagnutih zuba

**KRUNASTA GLAVA
ZA ISECANJE JEZGRA SDS MAX**

ŠIFRA	PREČNIK	UKUPNA DUŽINA	KUTIJA	€ /KOM.
72244	40mm	100mm	5	97,00
72245	50mm	100mm	12	105,00
72246	60mm	100mm	10	118,00
72247	65mm	100mm	10	124,00
72248	68mm	100mm	8	128,00
72249	80mm	100mm	8	140,00
72250	90mm	100mm	6	167,00
72251	100mm	100mm	6	192,00
72252	125mm	100mm	4	263,00

Sklopljeni set iz 3
dela

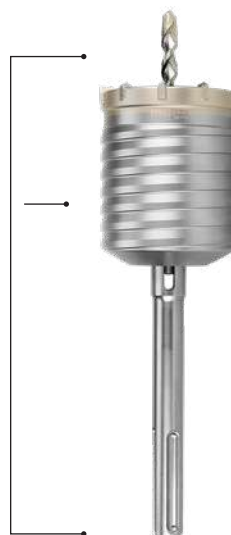

Telo:
Telo jezgra sa spoljašnjom spiralom



Kraj za umetanje:
SDS-MAX

- Primena: beton, cigla, zidovi
- Precizno izbušene rupe
- Veoma glatko bušenje zahvaljujući asimetričnom rasporedu zuba
- Smanjeno trenje i poboljšano uklanjanje prašine iz bušenja
- Izuzetno otporna konstrukcija
- Zamenjivi delovi



NEW



**SDS MAX ADAPTER
ZA UMETANJE**

ŠIFRA	UKUPNA DUŽINA	KUTIJA	€ /KOM.
72256	180mm	15	47,00
72257	450mm	10	68,00



NEW



**SDS MAX CENTRIRAJUĆI
NASTAVAK ZA BURGIJU**

ŠIFRA	PREČNIK	UKUPNA DUŽINA	KUTIJA	€ /KOM.
72253	11mm	120mm	50	8,70
72254	10mm	150mm	60	9,70



NEW



**KLJUČ SA DUGMETOM
ZA BRZO OTPUŠTANJE**

ŠIFRA	UKUPNA DUŽINA	KUTIJA	€ /KOM.
72255	140mm	100	8,20



*KOLIČINA PRI VIŠESTRUKOJ PORUČBINI

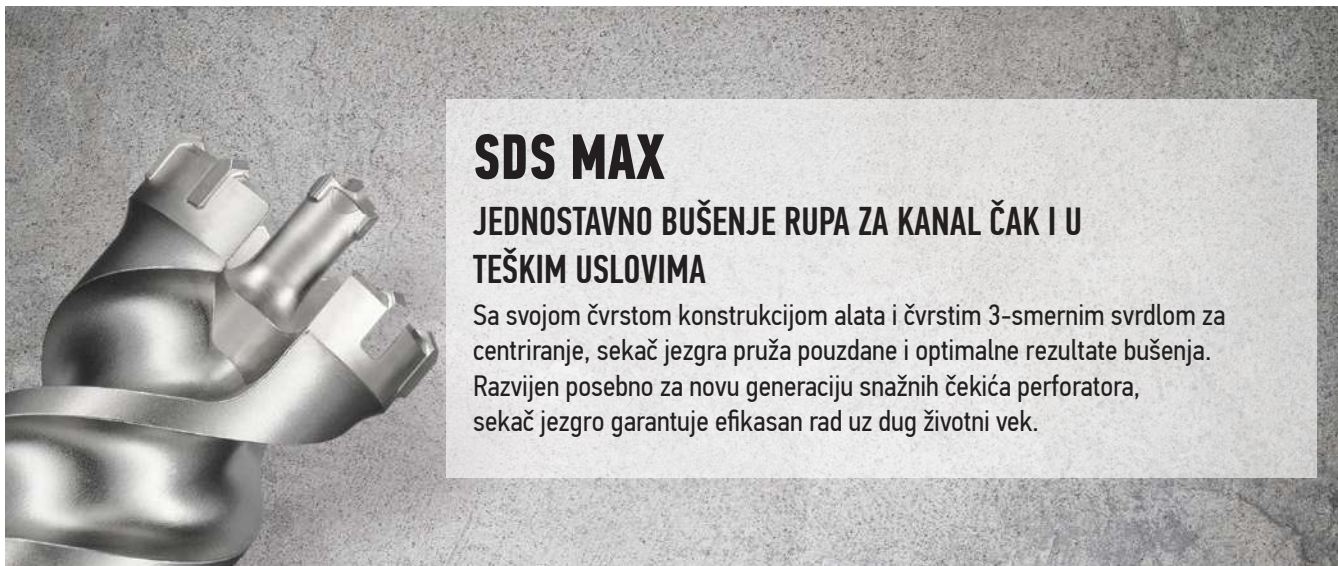

SDS MAX

JEDNOSTAVNO BUŠENJE RUPA ZA KANAL ČAK I U TEŠKIM USLOVIMA

Sa svojom čvrstom konstrukcijom alata i čvrstim 3-smernim svrdlom za centriranje, sekač jezgra pruža pouzdane i optimalne rezultate bušenja. Razvijen posebno za novu generaciju snažnih čekića perforatora, sekač jezgro garantuje efikasan rad uz dug životni vek.

NEW

UDARNA BURGIJA ZA BUŠENJE JEZGRA SDS MAX

ŠIFRA	PREČNIK	DUŽINA	KUTIJA	€ /KOM.
72235	40mm	550mm	5	205,00
72236	45mm	550mm	5	210,00
72237	45mm	990mm	3	248,00
72238	55mm	550mm	5	244,00
72239	55mm	990mm	3	286,00
72240	65mm	550mm	5	262,00
72241	65mm	990mm	2	317,00
72242	80mm	550mm	5	295,00
72243	80mm	990mm	2	390,00

- Razvijen posebno za novu generaciju snažnih čekića perforatora
- Bušenje rupe u betonu, cigli, zidovima, prirodnom kamenu
- Velika brzina bušenja
- Ugradjen centralni rezač sa krbidnim zubima
- Poboľjšano bušenje duboke rupe zahvaljujući brzom uklanjanju materijala
- Visoka otpornost na lom
- Smanjena vibracija

+30%
FASTER
EXTRACTION

+30%
MORE
DURABLE

WALL

BETON



Glava:
3-struki centrirani rezač
Karbidni zubi



Telo:
Trostruka spirala
Ojačano, kompaktno jezgro



Kraj za umetanje:
SDS-MAX

MADE IN
GERMANY

*KOLIČINA PRI VIŠESTRUKOJ PORUĐBINI

**BEST
SELLER** **MUST
HAVE**

**ZAŠILJENO DLETO
SDS MAX**

ŠIFRA	DUŽINA	KUTIJA	€/KOM.
74185	280mm	25	10,30
74186	400mm	15	11,60
74187	600mm	10	16,20



CrMo



**BEST
SELLER** **MUST
HAVE**

RAVNO DLETO SDS MAX

ŠIFRA	ŠIRINA	DUŽINA	KUTIJA	€/KOM.
74188	25mm	280mm	25	10,30
74189	25mm	400mm	15	11,60
74190	25mm	600mm	10	16,20



CrMo



**MUST
HAVE**

LOPATASTO DLETO, SDS MAX

ŠIFRA	ŠIRINA	DUŽINA	KUTIJA	€/KOM.
74191	80mm	300mm	20	22,00



CrMo



LOPATASTO DLETO, SDS MAX

ŠIFRA	ŠIRINA	DUŽINA	KUTIJA	€/KOM.
74192	115mm	350mm	10	46,00



CrMo



**MUST
HAVE**

**DLETO SA KRILCIMA
SDS MAX**

ŠIFRA	ŠIRINA	DUŽINA	KUTIJA	€/KOM.
74194	35mm	380mm	10	89,00



CrMo



BENMAN
PROFESSIONAL TOOLS

*KOLIČINA PRI VIŠESTRUKOJ PORUČBINI

BEST SELLER **MUST HAVE**

**ZAŠILJENO DLETO
SDS PLUS**

ŠIFRA	DUŽINA	KUTIJA	€/KOM.
74077	250mm	50	7,50



CrMo



BEST SELLER **MUST HAVE**

RAVNO DLETO SDS PLUS

ŠIFRA	ŠIRINA	DUŽINA	KUTIJA	€/KOM.
74078	20mm	250mm	50	7,50



CrMo



BEST SELLER **MUST HAVE**

LOPATASTO DLETO, SDS PLUS

ŠIFRA	ŠIRINA	DUŽINA	KUTIJA	€/KOM.
74079	40mm	250mm	40	11,60

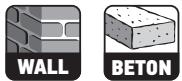

CrMo



MUST HAVE

**ŠUPLJE DLETO
ZA DUBLJENJE SDS PLUS**

ŠIFRA	ŠIRINA	DUŽINA	KUTIJA	€/KOM.
74080	22mm	250mm	30	17,00



CrMo



MUST HAVE

**DLETO SA KRILCIMA
SDS PLUS**

ŠIFRA	ŠIRINA	DUŽINA	KUTIJA	€/KOM.
74081	22mm	250mm	25	47,00



CrMo



BENMAN[®]
PROFESSIONAL TOOLS

*KOLIČINA PRI VIŠESTRUKOJ PORUČBINI

ZAŠILJENO DLETO HEX 30mm

ŠIFRA	DUŽINA	KUTIJA	€/KOM.
74474	400mm	7	48,00



CrMo



• Pogodan za: BOSCH, MAKITA, HITACHI, F.F. GROUP

PLJOSNATO DLETO, HEX 30mm

ŠIFRA	ŠIRINA	DUŽINA	KUTIJA	€/KOM.
74475	32mm	400mm	7	49,00



CrMo



• Pogodan za: HITACHI

LOPATASTO DLETO, HEX 30mm

ŠIFRA	ŠIRINA	DUŽINA	KUTIJA	€/KOM.
74476	100mm	400mm	5	73,00



CrMo



• Pogodan za: HITACHI

PLJOSNATO DLETO, HEX 30mm

ŠIFRA	ŠIRINA	DUŽINA	KUTIJA	€/KOM.
74477	32mm	400mm	7	49,00



CrMo



• Pogodan za: BOSCH, MAKITA, F.F. GROUP

LOPATASTO DLETO, HEX 30mm

ŠIFRA	ŠIRINA	DUŽINA	KUTIJA	€/KOM.
74478	100mm	400mm	5	73,00



CrMo



• Pogodan za: BOSCH, MAKITA, F.F. GROUP

TORZIONI UDAR

PATENTIRAN DIZAJN ZA
3 PUTA DUŽI VEK TRAJANJA

IDEALNO ZA ČEKIĆ BUŠILICE

V5
STEEL



TORZIONA moment zona
udvostručuje elastičnost,
radi sprečavanja loma

UDARNA moment zona
utrostručuje amortizaciju
radi sprečavanja loma

V5 hrom-vanadijum-
molibden čelik
visokog kvaliteta

BEST
SELLER

MUST
HAVE

V5
STEEL



PH TORZIONI UDAR BIT ZA ŠRAFLJENJE, 2 KOM

ŠIFRA	PROFIL	DUŽINA	PAKET	KUTLIJA	€ /PAK.
74928	PH1	25mm	2	20	1,80
74929	PH2	25mm	2	20	1,80
74930	PH3	25mm	2	20	1,80
74931	PH1	50mm	2	20	2,20
74932	PH2	50mm	2	20	2,20
74933	PH3	50mm	2	20	2,20
72201	PH1	75mm	2	15	3,80
72202	PH2	75mm	2	15	3,80
72203	PH3	75mm	2	15	3,80
72204	PH1	150mm	2	20	7,00
72205	PH2	150mm	2	20	7,00
72206	PH3	150mm	2	20	7,00



BEST
SELLER

MUST
HAVE

V5
STEEL



PH TORZIONI UDAR BIT ZA ŠRAFLJENJE

ŠIFRA	PROFIL	DUŽINA	PAKET	KUTLIJA	€ /PAK.
74112	PH1	25mm	15	12	7,00
74113	PH2	25mm	15	12	7,00
74114	PH3	25mm	15	12	7,00
74115	PH1	50mm	10	12	9,00
74116	PH2	50mm	10	12	9,00
74117	PH3	50mm	10	12	9,00



*KOLIČINA PRI VIŠESTRUKOJ PORUČBINI

BEST SELLER **MUST HAVE**
V5 STEEL

**PZ TORZIONI UDAR BIT
 ZA ŠRAFLJENJE, 2 KOM**

ŠIFRA	PROFIL	DUŽINA	PAKET	KUTIJA	€/PAK.
75019	PZ1	25mm	2	20	1,80
75020	PZ2	25mm	2	20	1,80
75021	PZ3	25mm	2	20	1,80
75022	PZ1	50mm	2	20	2,20
75023	PZ2	50mm	2	20	2,20
75024	PZ3	50mm	2	20	2,20
72207	PZ1	75mm	2	15	3,80
72208	PZ2	75mm	2	15	3,80
72209	PZ3	75mm	2	15	3,80
72210	PZ1	150mm	2	15	7,00
72211	PZ2	150mm	2	20	7,00
72212	PZ3	150mm	2	20	7,00

BEST SELLER **MUST HAVE**
V5 STEEL

**PZ TORZIONI UDAR BIT
 ZA ŠRAFLJENJE**

ŠIFRA	PROFIL	DUŽINA	PAKET	KUTIJA	€/PAK.
75013	PZ1	25mm	15	12	7,00
75014	PZ2	25mm	15	12	7,00
75015	PZ3	25mm	15	12	7,00
75016	PZ1	50mm	10	12	9,00
75017	PZ2	50mm	10	12	9,00
75018	PZ3	50mm	10	12	9,00

V5 STEEL

**SUPER PZ TORZIONI UDAR BIT
 ZA ŠRAFLJENJE, 2 KOM**

ŠIFRA	PROFIL	DUŽINA	PAKET	KUTIJA	€/PAK.
74942	PZ1	25mm	2	20	2,00
74943	PZ2	25mm	2	20	2,00
74944	PZ3	25mm	2	20	2,00
74945	PZ1	50mm	2	20	2,60
74946	PZ2	50mm	2	20	2,60
74947	PZ3	50mm	2	20	2,60



- Patentirani nastavak sa manjim dijagonalnim ivicama. bolje i dublje prijanjanje glave zavrtnja

V5 STEEL

**SUPER PZ TORZIONI UDAR BITI
 ZA ŠRAFLJENJE**

ŠIFRA	PROFIL	DUŽINA	PAKET	KUTIJA	€/PAK.
74126	PZ1	25mm	15	12	8,50
74127	PZ2	25mm	15	12	8,50
74128	PZ3	25mm	15	12	8,50
74129	PZ1	50mm	10	12	10,00
74130	PZ2	50mm	10	12	10,00
74131	PZ3	50mm	10	12	10,00



- Patentirani nastavak sa manjim dijagonalnim ivicama. bolje i dublje prijanjanje glave zavrtnja

MUST HAVE

V5 STEEL



**TORZIONI UDAR RAVAN BIT
ZA ŠRAFLJENJE, 2 KOM**

ŠIFRA	ŠIRINA	DUŽINA	DEBLJINA	PAKET	KUTIJA	€/PAK.
74934	4,0mm	25mm	0,5mm	2	20	1,80
74935	4,5mm	25mm	0,6mm	2	20	1,80
74936	5,5mm	25mm	0,8mm	2	20	1,80
74937	6,5mm	25mm	1,2mm	2	20	1,80
74938	4,0mm	50mm	0,5mm	2	20	2,20
74939	4,5mm	50mm	0,6mm	2	20	2,20
74940	5,5mm	50mm	0,8mm	2	20	2,20
74941	6,5mm	50mm	1,2mm	2	20	2,20
72213	4,0mm	75mm	0,5mm	2	15	3,80
72214	4,5mm	75mm	0,6mm	2	15	3,80
72215	5,5mm	75mm	0,8mm	2	15	3,80
72216	6,5mm	75mm	1,2mm	2	15	3,80
72217	4,0mm	150mm	0,5mm	2	20	7,00
72218	4,5mm	150mm	0,6mm	2	20	7,00
72219	5,5mm	150mm	0,8mm	2	20	7,00
72220	6,5mm	150mm	1,2mm	2	20	7,00

MUST HAVE

V5 STEEL



**TORZIONI UDAR RAVAN BIT
ZA ŠRAFLJENJE**

ŠIFRA	ŠIRINA	DUŽINA	DEBLJINA	PAKET	KUTIJA	€/PAK.
74118	4,0mm	25mm	0,5mm	15	12	7,00
74119	4,5mm	25mm	0,6mm	15	12	7,00
74120	5,5mm	25mm	0,8mm	15	12	7,00
74121	6,5mm	25mm	1,2mm	15	12	7,00
74122	4,0mm	50mm	0,5mm	10	12	9,00
74123	4,5mm	50mm	0,6mm	10	12	9,00
74124	5,5mm	50mm	0,8mm	10	12	9,00
74125	6,5mm	50mm	1,2mm	10	12	9,00

MUST HAVE

V5 STEEL



**ROBERTSON TORZIONI UDAR BIT
ZA ŠRAFLJENJE, 2 KOM**

ŠIFRA	PROFIL	DUŽINA	PAKET	KUTIJA	€/PAK.
74976	R1	25mm	2	20	1,80
74977	R2	25mm	2	20	1,80
74978	R3	25mm	2	20	1,80
74979	R1	50mm	2	20	2,20
74980	R2	50mm	2	20	2,20
74981	R3	50mm	2	20	2,20



MUST HAVE

V5 STEEL



**ROBERTSON TORZIONI UDAR BIT
ZA ŠRAFLJENJE**

ŠIFRA	PROFIL	DUŽINA	PAKET	KUTIJA	€/PAK.
74040	R1	25mm	15	12	7,00
74195	R2	25mm	15	12	7,00
74196	R3	25mm	15	12	7,00
74197	R1	50mm	10	12	9,00
74198	R2	50mm	10	12	9,00
74199	R3	50mm	10	12	9,00



*KOLIČINA PRI VIŠESTRUKOJ PORUDŽBINI

MUST HAVE
V5 STEEL

**TORX TORZIONI UDAR BIT
 ZA ŠRAFLJENJE, 2 KOM**

ŠIFRA	PROFIL	DUŽINA	PAKET	KUTIJA	€/PAK.
74948	T10	25mm	2	20	2,00
74949	T15	25mm	2	20	2,00
74950	T20	25mm	2	20	2,00
74951	T25	25mm	2	20	2,00
74952	T27	25mm	2	20	2,00
74953	T30	25mm	2	20	2,00
74954	T40	25mm	2	20	2,00
74955	T10	50mm	2	20	2,50
74956	T15	50mm	2	20	2,50
74957	T20	50mm	2	20	2,50
74958	T25	50mm	2	20	2,50
74959	T27	50mm	2	20	2,50
74960	T30	50mm	2	20	2,50
74961	T40	50mm	2	20	2,50
72187	T10	75mm	2	15	3,80
72188	T15	75mm	2	15	3,80
72189	T20	75mm	2	15	3,80
72190	T25	75mm	2	15	3,80
72191	T27	75mm	2	15	3,80
72192	T30	75mm	2	15	3,80
72193	T40	75mm	2	15	3,80
72194	T10	150mm	2	20	7,00
72195	T15	150mm	2	20	7,00
72196	T20	150mm	2	20	7,00
72197	T25	150mm	2	20	7,00
72198	T27	150mm	2	20	7,00
72199	T30	150mm	2	20	7,00
72200	T40	150mm	2	20	7,00



*KOLIČINA PRI VIŠESTRUKOJ PORUČBINI

MUST HAVE
V5 STEEL

**TORX TORZIONI UDAR BIT
 ZA ŠRAFLJENJE**

ŠIFRA	PROFIL	DUŽINA	PAKET	KUTIJA	€/PAK.
74132	T10	25mm	15	12	7,00
74133	T15	25mm	15	12	7,00
74134	T20	25mm	15	12	7,00
74135	T25	25mm	15	12	7,00
74136	T27	25mm	15	12	7,00
74137	T30	25mm	15	12	7,00
74138	T40	25mm	15	12	7,00
74139	T10	50mm	10	12	9,00
74140	T15	50mm	10	12	9,00
74141	T20	50mm	10	12	9,00
74142	T25	50mm	10	12	9,00
74143	T27	50mm	10	12	9,00
74144	T30	50mm	10	12	9,00
74145	T40	50mm	10	12	9,00

NEW
MUST HAVE
V5 STEEL

**TORX TORZIONI UDAR BIT
 ZA ŠRAFLJENJE SA ZAŠTITOM
 OD ODVIJANJA, 2 KOM**

ŠIFRA	PROFIL	DUŽINA	PAKET	KUTIJA	€/PAK.
72173	TR10	25mm	2	20	2,00
72174	TR15	25mm	2	20	2,00
72175	TR20	25mm	2	20	2,00
72176	TR25	25mm	2	20	2,00
72177	TR27	25mm	2	20	2,00
72178	TR30	25mm	2	20	2,00
72179	TR40	25mm	2	20	2,00
72180	TR10	50mm	2	20	2,50
72181	TR15	50mm	2	20	2,50
72182	TR20	50mm	2	20	2,50
72183	TR25	50mm	2	20	2,50
72184	TR27	50mm	2	20	2,50
72185	TR30	50mm	2	20	2,50
72186	TR40	50mm	2	20	2,50



MUST HAVE
V5 STEEL

**HEX TORZION I UDAR BIT
 ZA ŠRAFLJENJE, 2 KOM**

ŠIFRA	PREČNIK	DUŽINA	PAKET	KUTIJA	€/PAK.
74962	2,0mm	25mm	2	20	1,80
74963	2,5mm	25mm	2	20	1,80
74964	3,0mm	25mm	2	20	1,80
74965	4,0mm	25mm	2	20	1,80
74966	5,0mm	25mm	2	20	1,80
74967	6,0mm	25mm	2	20	1,80
74969	2,0mm	50mm	2	20	2,20
74970	2,5mm	50mm	2	20	2,20
74971	3,0mm	50mm	2	20	2,20
74972	4,0mm	50mm	2	20	2,20
74973	5,0mm	50mm	2	20	2,20
74974	6,0mm	50mm	2	20	2,20

MUST TRY
S2 STEEL

**PZ POWER GRIP BIT
 ZA ŠRAFLJENJE, 20 KOM**

ŠIFRA	PROFIL	DUŽINA	PAKET	KUTIJA	€/PAK.
74999	PZ1	25mm	20	20	5,00
75000	PZ2	25mm	20	20	5,00
75001	PZ3	25mm	20	20	5,00



- Snažno prijanjanje, neklizajuće
- 30% duži život od uobičajenih bitova

**+30%
 LONGER
 LIFE**
MUST TRY
S2 STEEL

**PH POWER GRIP BIT
 ZA ŠRAFLJENJE, 20 KOM**

ŠIFRA	PROFIL	DUŽINA	PAKET	KUTIJA	€/PAK.
74996	PH1	25mm	20	20	5,00
74997	PH2	25mm	20	20	5,00
74998	PH3	25mm	20	20	5,00



- Snažno prijanjanje, neklizajuće
- 30% duži život od uobičajenih bitova

**+30%
 LONGER
 LIFE**
BEST SELLER MUST HAVE
S2 STEEL

- Posebna obloga za amortizaciju

MAGNETNI POSTAVLJAČ NAVRTKI S2 ČELIK

ŠIFRA	PREČNIK	DUŽINA	KUTIJA	€/KOM.
74022	6mm	65mm	10	5,00
74023	7mm	65mm	10	5,00
74026	8mm	65mm	10	5,00
74027	10mm	65mm	10	5,20
74028	11mm	65mm	10	5,20
74029	12mm	65mm	10	5,40
74030	13mm	65mm	10	5,40
74082	14mm	65mm	10	5,80

NEW

BIT SA GRANIČNIKOM ZA GIPS, PH2, 2 KOM

ŠIFRA	PAKET	€/PAK.
72516	2	2,60

- Specijalni umetak - adapter sa stopom, za šrafljenje u gipsane ploče
- Zaustavlja šraf na određenoj dubini, kako bi se izbeglo dalje ulegnuće

*KOLIČINA PRI VIŠESTRUKOJ PORUČBINI

**BEST
SELLER**

**TORZIONI UDAR BIT
ZA ŠRAFLJENJE, 31 KOM**

ŠIFRA	ŠIRINA	VISINA	DUBINA	KUTIJA	€ /SET
74150	10cm	6,5cm	3cm	12	21,00



**V5
STEEL**

UKLJUČUJE

TORX: T10/ T15/ 3xT20/ 3xT25/
T30/ T40
PHILLIPS: PH1/ 5xPH2/ PH3
ŠESTOUGAO: 3/ 4/ 5mm
POZIDRIV: PZ1/ 3xPZ2/ PZ3
ROBERTSON: R1/ R2
RAVAN: 4,5/ 6,5/ 8mm
Adapter za brzo oslobađanje

**BEST
SELLER NICE
TO HAVE**

**TORZIONI UDAR BIT
ZA ŠRAFLJENJE, 10 KOM**

ŠIFRA	ŠIRINA	VISINA	DUBINA	KUTIJA	€ /SET
74149	10cm	5cm	1,5cm	12	15,00



UKLJUČUJE

PHILLIPS: PH1/ 2xPH2
POZIDRIV: 2xPZ2
TORX: T25/ T27/ 2xT30
Magnetni držač umetka



**V5
STEEL**

**BEST
SELLER**

**MUST
TRY**



INOX



MAGNETNI DRŽAČ ZA BIT, QUICK LOCK

ŠIFRA	DUŽINA	KUTIJA	€ /KOM.
70399	75mm	10	7,20

- Dodatni magnetni prsten koji omogućava da se zadrže vrlo dugački šrafovi a da ne padnu



DRŽAČ BITOVA BRZO-ZAMENLJIVI

ŠIFRA	DUŽINA	KUTIJA	€ /KOM.
74148	60mm	10	7,00



**BEST
SELLER MUST
HAVE**



MAGNETNI DRŽAČ ZA BIT

ŠIFRA	DUŽINA	KUTIJA	€ /KOM.
74146	60mm	10	3,20
74147	75mm	10	3,80

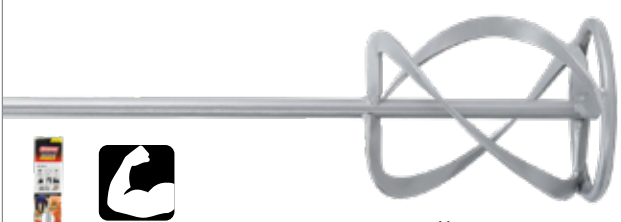
*KOLIČINA PRI VIŠESTRUKOJ PORUČBINI

MIKSER ZA MEŠANJE MK M14 ZA BETON



ŠIFRA	OTVOR	MODEL	PREČNIK	DUŽINA	OPTEREĆENJE ZA MEŠANJE	RPM	KUTIJA	€/KOM.
71792	M14	MK 120M	120mm	590mm	15-25kg	400 - 500min ⁻¹	6	41,00
71793	M14	MK 140M	135mm	590mm	25-40kg	200 - 300min ⁻¹	5	43,00
71794	M14	MK 160M	160mm	590mm	30-60kg	200 - 300min ⁻¹	2	47,00

• Maltera
 • Beton
 • Gips
 • Lepak za pločice
 • Epoksid ispunjen kvarcom

BETON ★★★★★
BOJE ZA ZIDOVE ☆☆☆☆
GIPS ★★★★★
LEPAK ZA PLOČICE ★★★★★

MIXING EFFECT ↑

MADE IN GERMANY

MIKSER ZA MEŠANJE MKN M14 ZA MALTER

ŠIFRA	OTVOR	MODEL	PREČNIK	DUŽINA	OPTEREĆENJE ZA MEŠANJE	RPM	KUTIJA	€/KOM.
71795	M14	MKN 120M	120mm	590mm	15-25kg	400 - 600min ⁻¹	6	41,00

• Gips
• Boje za zidove

BETON ★★☆☆☆
BOJE ZA ZIDOVE ★★★★★
GIPS ★★★★★
LEPAK ZA PLOČICE ★★☆☆☆

MIXING EFFECT ↓

MADE IN GERMANY

BEST SELLER **MUST HAVE**

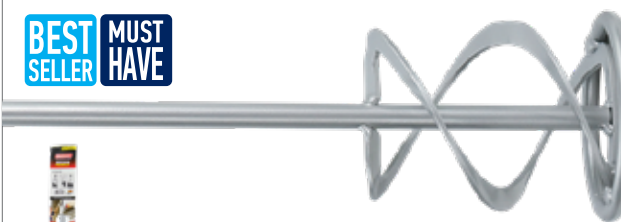

MIKSER ZA MEŠANJE WK M14 ZA LEPAK ZA PLOČICE I GIPSANI MALTER



ŠIFRA	OTVOR	MODEL	PREČNIK	DUŽINA	OPTEREĆENJE ZA MEŠANJE	RPM	KUTIJA	€/KOM.
71804	M14	WK 120M	120mm	590mm	10-15kg	500 - 700min ⁻¹	6	32,00

• Maltera
• Beton
• Gips
• Lepak za pločice

BETON ★★★★★
BOJE ZA ZIDOVE ☆☆☆☆
GIPS ★★★★★
LEPAK ZA PLOČICE ★★★★★

MIXING EFFECT ↑

MADE IN GERMANY

MIKSER ZA MEŠANJE DLX M14 ZA LEPAK ZA PLOČICE I MALTER

ŠIFRA	OTVOR	MODEL	PREČNIK	DUŽINA	OPTEREĆENJE ZA MEŠANJE	RPM	KUTIJA	€/KOM.
71962	M14	DLX 120M	120mm	590mm	20-40kg	500 - 700min ⁻¹	6	39,00
71963	M14	DLX 152M	150mm	590mm	40-65kg	600 - 700min ⁻¹	2	57,00

• Smesa za nivelisanje
• Tanki beton
• Tečni premazi
• Zaptivanje bez bituma

BETON ★☆☆☆☆
BOJE ZA ZIDOVE ★★☆☆☆
GIPS ★★★★★
LEPAK ZA PLOČICE ★★☆☆☆

MIXING EFFECT ↓

MADE IN GERMANY

*KOLIČINA PRI VIŠESTRUKOJ PORUČBINI

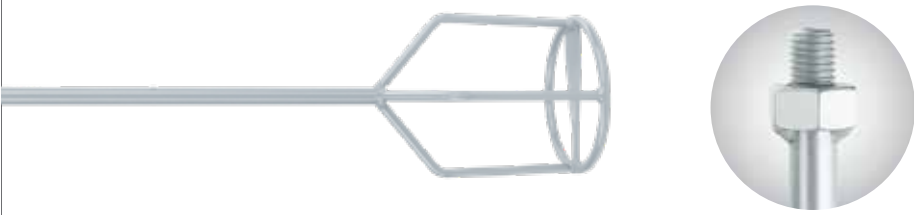

MIKSER ZA MEŠANJE KR M14 ZA LEPAK ZA PLOČICE I ZAPTIVNE MASE

ŠIFRA	OTVOR	MODEL	PREČNIK	DUŽINA	OPTEREĆENJE ZA MEŠANJE	RPM	KUTIJA	€/KOM.
71964	M14	KR 120M	120mm	590mm	15-25kg	400 - 600min ⁻¹	6	34,00
71965	M14	KR 140M	140mm	590mm	20-35kg	400 - 600min ⁻¹	5	42,00

BETON ★★☆☆☆
BOJE ZA ZIDOVE ★★☆☆☆
GIPS ★★☆☆☆
LEPAK ZA PLOČICE ★★☆☆☆

MIXING EFFECT ←

- Materijali za popunjavanje podova
- Beton
- Zaptivanje
- Lepak za pločice

MADE IN GERMANY

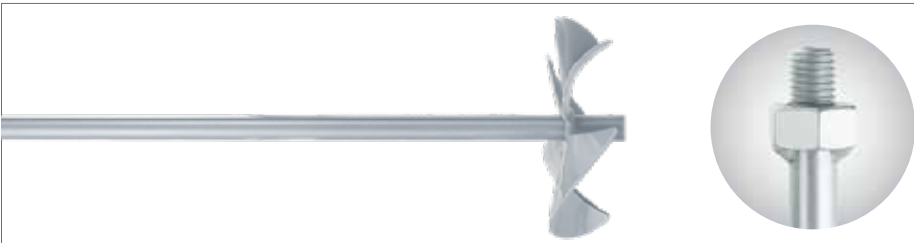

MIKSER ZA MEŠANJE LX M14 ZA BOJE

ŠIFRA	OTVOR	MODEL	PREČNIK	DUŽINA	OPTEREĆENJE ZA MEŠANJE	RPM	KUTIJA	€/KOM.
71966	M14	X120M	120mm	590mm	15-25kg	600 - 700min ⁻¹	6	22,00

BETON ★☆☆☆☆
BOJE ZA ZIDOVE ★★☆☆☆
GIPS ★☆☆☆☆
LEPAK ZA PLOČICE ★☆☆☆☆

MIXING EFFECT ↓

- Boje za zidove
- Prajmeri
- Epoksidna smola

MADE IN GERMANY



MIKSER ZA MEŠANJE LX ZA BOJE

ŠIFRA	OTVOR	MODEL	GLAVA	PREČNIK	DUŽINA	OPTEREĆENJE ZA MEŠANJE	RPM	KUTIJA	€/KOM.
71796	HEX 10	LX70S	10mm	70mm	400mm	0-15kg	600 - 700min ⁻¹	16	5,00

BETON ☆☆☆☆☆
BOJE ZA ZIDOVE ★★☆☆☆
GIPS ★☆☆☆☆
LEPAK ZA PLOČICE ★☆☆☆☆

MIXING EFFECT ↓

- Boje za zidove
- Prajmeri
- Epoksidna smola

MADE IN GERMANY



MIKSER ZA MEŠANJE UR ZA BOJE

ŠIFRA	OTVOR	MODEL	GLAVA	PREČNIK	DUŽINA	OPTEREĆENJE ZA MEŠANJE	RPM	KUTIJA	€/KOM.
71797	HEX 10	UR60S	10mm	60mm	400mm	0-5kg	500 - 700min ⁻¹	16	10,50
71798	HEX 10	UR80S	10mm	80mm	400mm	5-10kg	500 - 700min ⁻¹	12	11,50
71799	HEX 13	UR100S	13mm	100mm	590mm	10-25kg	400 - 700min ⁻¹	6	16,50
71800	HEX 13	UR120S	13mm	120mm	590mm	20-30kg	400 - 600min ⁻¹	6	19,00

BETON ★☆☆☆☆
BOJE ZA ZIDOVE ★★☆☆☆
GIPS ★★☆☆☆
LEPAK ZA PLOČICE ★★☆☆☆

MIXING EFFECT ↓

- Boje za zidove
- Lakovi
- Prajmeri
- Kremasti gips

MADE IN GERMANY

*KOLIČINA PRI VIŠESTRUKOJ PORUČBINI



MIKSER ZA MEŠANJE MM ZA LEPAK ZA PLOČICE I GIPSANI MALTER

ŠIFRA	OTVOR	GLAVA	PREČNIK	DUŽINA	MIXING CAPACITY	RPM	KUTIJA	€/KOM.
71801	HEX 10	10mm	85mm	400mm	5-10kg	700 - 900min ⁻¹	12	11,50

BETON ★★★★★
BOJE ZA ZIDOVE ☆☆☆☆
GIPS ★★★★★
LEPAK ZA PLOČICE ★★★★★

MIXING EFFECT ↑

- Lepak za pločice
- Maltera

MADE IN GERMANY



MIKSER ZA MEŠANJE WK ZA LEPAK ZA PLOČICE I GIPSANI MALTER

ŠIFRA	OTVOR	GLAVA	PREČNIK	DUŽINA	OPTEREĆENJE ZA MEŠANJE	RPM	KUTIJA	€/KOM.
71802	HEX 13	13mm	100mm	590mm	10-15kg	400 - 500min ⁻¹	6	21,00

BETON ★★★★★
BOJE ZA ZIDOVE ☆☆☆☆
GIPS ★★★★★
LEPAK ZA PLOČICE ★★★★★

MIXING EFFECT ↑

- Maltera
- Beton
- Gips
- Lepak za pločice

MADE IN GERMANY



MIKSER ZA MEŠANJE WK ZA LEPAK ZA PLOČICE I GIPSANI MALTER

ŠIFRA	OTVOR	GLAVA	PREČNIK	DUŽINA	OPTEREĆENJE ZA MEŠANJE	RPM	KUTIJA	€/KOM.
71803	HEX 13	13mm	120mm	590mm	15-25kg	400 - 500min ⁻¹	6	26,00

BETON ★★★★★
BOJE ZA ZIDOVE ☆☆☆☆
GIPS ★★★★★
LEPAK ZA PLOČICE ★★★★★

MIXING EFFECT ↑

- Maltera
- Beton
- Gips
- Lepak za pločice

MADE IN GERMANY

NEW



MIKSER ZA MEŠANJE PXV ZA LEPAK ZA PLOČICE I FILERE

ŠIFRA	OTVOR	PREČNIK	DUŽINA	OPTEREĆENJE ZA MEŠANJE	RPM	KUTIJA	€/KOM.
72033	HEX 10	170mm	560mm	30-50kg	400 - 500min ⁻¹	20	21,00

BETON ☆☆☆☆
BOJE ZA ZIDOVE ☆☆☆☆
GIPS ★★★★★
LEPAK ZA PLOČICE ★★★★★

MIXING EFFECT ↑

- Lepak za pločice
- Fileri

MADE IN EU

*KOLIČINA PRI VIŠESTRUKOJ PORUČBINI



1. Izaberite list testere koji najbolje ispunjava vaše potrebe u skladu sa materijalom koji se seče:



2. Izaberite odgovarajući list testere za najbolje sečenje:



Čelik sa visokim sadržajem ugljenika:
za drvo i metal



Karbidna granulacija od volframa:
karbidni sloj za veoma zahtevne zadatke
i veliku izdržljivost



Čelik velike brzine:
za drvo, metal i plastiku



Karbidni zupci od volframa:
karbidni zupci za veoma zahtevne zadatke
i veliku izdržljivost



8% COBALT

Dvometalni, sa 8% kobalta:
za veoma zahtevne zadatke i veliku izdržljivost

3. Pažljivo pročitajte indeks simbola svakog blistera i saznajte korisne informacije o zupcima po inču, debljina materijala ili tehnike sečenja:



Za pravi rez



Za čist rez



Za okrugli rez



Debljina
materijala u mm



Za precizni rez
drva i metala



Za brzi rez

BASIC CUT



LIST ZA UBODNU TESTERU BASIC CUT
ZA MEKO DRVO, 5 KOM

ŠIFRA	BOSCH TIP	DUŽINA SEČIVA	ŠIRINA	DEBLJINA	TPI	KUTIJA	€/PAK.
71856	T111 C	100mm	9,8mm	1,3mm	8	10*	3,20

• Brušene, set



BASIC CUT



LIST ZA UBODNU TESTERU BASIC CUT
ZA MEKO DRVO, 5 KOM

ŠIFRA	BOSCH TIP	DUŽINA SEČIVA	ŠIRINA	DEBLJINA	TPI	KUTIJA	€/PAK.
71855	U111 C	100mm	9,8mm	1,3mm	8	10*	3,20

• Brušene, set, pogodno za Black&Decker



BASIC CUT



LIST ZA UBODNU TESTERU BASIC CUT
ZA ŠPER PLOČE, 5 KOM

ŠIFRA	BOSCH TIP	DUŽINA SEČIVA	ŠIRINA	DEBLJINA	TPI	KUTIJA	€/PAK.
71858	T119 B0	76mm	5,0mm	1,0mm	12	10*	3,40

• Brušene, set



BEST SELLER **MUST HAVE**

CLEAN CUT



LIST ZA UBODNU TESTERU CLEAN CUT
ZA MEKO DRVO, 5 KOM

ŠIFRA	BOSCH TIP	DUŽINA SEČIVA	ŠIRINA	DEBLJINA	TPI	KUTIJA	€/PAK.
71853	T101 D	100mm	7,8mm	1,5mm	6	10*	4,00

• Krstasti, konusni



*KOLIČINA PRI VIŠESTRUKOJ PORUČBINI

BEST SELLER **MUST HAVE**

CLEAN CUT



LIST ZA UBODNU TESTERU CLEAN CUT
ZA MEKO DRVO, 5 KOM



ŠIFRA	BOSCH TIP	DUŽINA SEČIVA	ŠIRINA	DEBLJINA	TPI	KUTIJA	€ /PAK.
71863	T301 DL	132mm	7,8mm	1,5mm	6	10*	5,90

• Krstasti, konusni



CLEAN CUT



LIST ZA UBODNU TESTERU CLEAN CUT
ZA ŠPER PLOČE I IVERICU, 5 KOM



ŠIFRA	BOSCH TIP	DUŽINA SEČIVA	ŠIRINA	DEBLJINA	TPI	KUTIJA	€ /PAK.
71859	T101 BR	100mm	7,8mm	1,5mm	10	10*	4,00

• Krstasti, konusni



BEST SELLER **MUST HAVE**

CLEAN CUT



LIST ZA UBODNU TESTERU CLEAN CUT
ZA MEKO DRVO I MDF, 5 KOM



ŠIFRA	BOSCH TIP	DUŽINA SEČIVA	ŠIRINA	DEBLJINA	TPI	KUTIJA	€ /PAK.
71854	T101 B	100mm	7,8mm	1,5mm	10	10*	4,00

• Krstasti, konusni



BEST SELLER

CLEAN CUT



LIST ZA UBODNU TESTERU CLEAN CUT
ZA ŠPER PLOČE I MDF, 5 KOM



ŠIFRA	BOSCH TIP	DUŽINA SEČIVA	ŠIRINA	DEBLJINA	TPI	KUTIJA	€ /PAK.
71864	U101 B	100mm	7,8mm	1,5mm	10	10*	4,60

• Krstasti konusni, pogodno za Black&Decker



*KOLIČINA PRI VIŠESTRUKOJ PORUČBINI

CLEAN CUT



**LIST ZA UBODNU TESTERU CLEAN CUT
ZA ŠPER PLOČE, 5 KOM**

ŠIFRA	BOSCH TIP	DUŽINA SEČIVA	ŠIRINA	DEBLJINA	TPI	KUTIJA	€ /PAK.
71857	T234 X	115mm	10,0mm	1,5mm	9	10*	6,20

• Krstasti, konusni

BEST SELLER **MUST HAVE**

FAST CUT



**LIST ZA UBODNU TESTERU FAST CUT
ZA MEKO DRVO, 5 KOM**

ŠIFRA	BOSCH TIP	DUŽINA SEČIVA	ŠIRINA	DEBLJINA	TPI	KUTIJA	€ /PAK.
71850	T144 D	100mm	7,8mm	1,3mm	6	10*	3,70

• Brušene, set

BEST SELLER **MUST HAVE**

FAST CUT



**LIST ZA UBODNU TESTERU FAST CUT
ZA MEKO DRVO, 5 KOM**

ŠIFRA	BOSCH TIP	DUŽINA SEČIVA	ŠIRINA	DEBLJINA	TPI	KUTIJA	€ /PAK.
71862	T344 D	132mm	7,8mm	1,3mm	6	10*	5,90

• Brušene, set

MUST HAVE

MAXPOWER



**LIST ZA UBODNU TESTERU MAXPOWER
ZA LAMINAT, 5 KOM**

ŠIFRA	BOSCH TIP	DUŽINA SEČIVA	ŠIRINA	DEBLJINA	TPI	KUTIJA	€ /PAK.
71871	T101 BIF	80mm	7,9mm	1,3mm	13	10	8,40

• Krstasti, konusni

*KOLIČINA PRI VIŠESTRUKOJ PORUČBINI

MUST
HAVE

MAXPOWER



LIST ZA UBODNU TESTERU MAXPOWER
ZA TVRDO DRVO, 5 KOM

ŠIFRA	BOSCH TIP	DUŽINA SEČIVA	ŠIRINA	DEBLJINA	TPI	€/PAK.
71872	T101 BF	100mm	7,8mm	1,5mm	10	8,80

• Brušene, set



BASIC CUT



LIST ZA UBODNU TESTERU BASIC CUT
ZA METAL, 5 KOM

ŠIFRA	BOSCH TIP	DUŽINA SEČIVA	ŠIRINA	DEBLJINA	TPI	KUTIJA	€/PAK.
71852	T118 A	75mm	7,8mm	1,0mm	21	10*	4,00

• Brušene, set



BASIC CUT



LIST ZA UBODNU TESTERU BASIC CUT
ZA METAL, 5 KOM

ŠIFRA	BOSCH TIP	DUŽINA SEČIVA	ŠIRINA	DEBLJINA	TPI	€/PAK.
71860	U118 A	75mm	7,8mm	1,0mm	21	4,60

• Brušene, set, pogodno za Black&Decker



BASIC CUT



LIST ZA UBODNU TESTERU BASIC CUT
ZA METAL, 5 KOM

ŠIFRA	BOSCH TIP	DUŽINA SEČIVA	ŠIRINA	DEBLJINA	TPI	KUTIJA	€/PAK.
71868	T118 B	75mm	7,8mm	1,0mm	12	10*	4,20

• Brušene, set



*KOLIČINA PRI VIŠESTRUKOJ PORUČBINI

BASIC CUT



LIST ZA UBODNU TESTERU BASIC CUT
ZA METAL I NERĐAJUĆI METAL, 5 KOM

ŠIFRA	BOSCH TIP	DUŽINA SEČIVA	ŠIRINA	DEBLJINA	TPI	€/PAK.
71867	T318 A	132mm	9,8mm	1,0mm	21	7,60

• Brušene, set

BEST SELLER **MUST HAVE**

FAST CUT



LIST ZA UBODNU TESTERU FAST CUT
ZA METAL I NERĐAJUĆI METAL, 5 KOM

ŠIFRA	BOSCH TIP	DUŽINA SEČIVA	ŠIRINA	DEBLJINA	TPI	KUTIJA	€/PAK.
71849	T127 D	100mm	7,8mm	1,0mm	8	10*	6,60

• Brušene, set

BEST SELLER **MUST HAVE**

MAXPOWER



LIST ZA UBODNU TESTERU MAXPOWER
ZA METAL I INOKS, 5 KOM

ŠIFRA	BOSCH TIP	DUŽINA SEČIVA	ŠIRINA	DEBLJINA	TPI	KUTIJA	€/PAK.
71866	T118 AF	75mm	7,8mm	1,0mm	21	10*	5,80

• Brušene, set

BEST SELLER **MUST HAVE**

MAXPOWER



LIST ZA UBODNU TESTERU MAXPOWER
ZA METAL I NERĐAJUĆI METAL, 5 KOM

ŠIFRA	BOSCH TIP	DUŽINA SEČIVA	ŠIRINA	DEBLJINA	TPI	KUTIJA	€/PAK.
71851	T123 XF	100mm	9,8mm	1,0mm	2,5	10*	6,10

• Brušene, set

*KOLIČINA PRI VIŠESTRUKOJ PORUČBINI

**BEST
SELLER** **MUST
HAVE**

MAXPOWER



**LIST ZA UBODNU TESTERU MAXPOWER
ZA SENDVIČ PANEL I NERĐAJUĆI METAL, 5 KOM**



ŠIFRA	BOSCH TIP	DUŽINA SEČIVA	ŠIRINA	DEBLJINA	TPI	€ /PAK.
71865	T318 AF	132mm	9,8mm	1,0mm	21	8,80

• Brušene, set



**MUST
HAVE**

MAXPOWER



**LIST ZA UBODNU TESTERU MAXPOWER
ZA SENDVIČ PANEL, 5 KOM**



ŠIFRA	BOSCH TIP	DUŽINA SEČIVA	ŠIRINA	DEBLJINA	TPI	€ /PAK.
71887	T718 BF	200mm	9,8mm	1,0mm	18	14,50

• Brušene, set



**NICE
TO HAVE**

MAXPOWER



**LIST ZA UBODNU TESTERU MAXPOWER
ZA DRVO I METAL, 5 KOM**



ŠIFRA	BOSCH TIP	DUŽINA SEČIVA	ŠIRINA	DEBLJINA	TPI	€ /PAK.
71861	T345 XF	132mm	9,8mm	1,0mm		9,40

• Brušene, set



**MUST
HAVE**

SPECIAL



**LIST ZA UBODNU TESTERU MAXPOWER
ZA KERAMIKU, 3 KOM**



ŠIFRA	BOSCH TYPE	DUŽINA SEČIVA	ŠIRINA	DEBLJINA	KUTIJA	€ /PAK.
71987	T130 Riff	75mm	7,8mm	1,3mm	10	11,00

• Karbidna granulacija od volframa



*KOLIČINA PRI VIŠESTRUKOJ PORUČBINI

SPECIAL



**LIST ZA UBODNU TESTERU MAXPOWER
ZA PLASTIKU, 2 KOM**

ŠIFRA	BOSCH TYPE	DUŽINA SEČIVA	ŠIRINA	DEBLJINA	TPI	KUTIJA	€/PAK.
71870	T141 HM	100mm	7,8mm	1,3mm	6	10	28,60

• Karbidni zupci od volframa



MUST HAVE

SPECIAL



**LIST ZA UBODNU TESTERU MAXPOWER
ZA PLASTIKU I AKRIL, 5 KOM**

ŠIFRA	BOSCH TIP	DUŽINA SEČIVA	ŠIRINA	DEBLJINA	TPI	KUTIJA	€/PAK.
71986	T101 A	100mm	7,8mm	1,3mm	12	10	7,60

• krstasti, konusni



*KOLIČINA PRI VIŠESTRUKOJ PORUČBINI

BASIC CUT



LIST ZA SABLJASTU TESTERU, BASIC CUT,
ZA MEKO DRVO, 5 KOM

ŠIFRA	BOSCH TIP	DUŽINA SEČIVA	ŠIRINA	DEBLJINA	TPI	€/PAK.
71886	S 617K	150mm	19mm	1,1mm	3	10,00

• Brušene, set



MUST HAVE

BASIC CUT



LIST ZA SABLJASTU TESTERU, BASIC CUT,
ZA MEKO I SIROVO DRVO, 5 KOM

ŠIFRA	BOSCH TIP	DUŽINA SEČIVA	ŠIRINA	DEBLJINA	TPI	€/PAK.
71879	S 1617K	300mm	19mm	1,3mm	3	12,40

• Brušene, set



MUST HAVE

CLEAN CUT



LIST ZA SABLJASTU TESTERU, CLEAN CUT,
ZA ŠPER PLOČE, 5 KOM

ŠIFRA	BOSCH TYPE	DUŽINA SEČIVA	ŠIRINA	DEBLJINA	TPI	€/PAK.
71874	S 2345 X	240mm	19mm	1,8mm	7	27,60

• Krstasti, konusni



MUST HAVE

FAST CUT



LIST ZA SABLJASTU TESTERU, FAST CUT,
ZA MEKO DRVO, 5 KOM

ŠIFRA	BOSCH TYPE	DUŽINA SEČIVA	ŠIRINA	DEBLJINA	TPI	€/PAK.
71873	S 1531 L	240mm	19mm	1,3mm	4-5	13,20

• Krstasti, set



*KOLIČINA PRI VIŠESTRUKOJ PORUČBINI

FAST CUT



LIST ZA SABLJASTU TESTERU, FAST CUT,
ZA MEKO I SIROVO DRVO, 5 KOM

ŠIFRA	BOSCH TIP	DUŽINA SEČIVA	ŠIRINA	DEBLJINA	TPI	€/PAK.
71889	S 1542 K	240mm	19mm	1,3mm	4	17,50

• Krstasti, set



CURVE CUT



LIST ZA SABLJASTU TESTERU, CURVE CUT,
ZA MDF, KUH. RAD. POVRŠ. I PLAST., 5 KOM

ŠIFRA	BOSCH TIP	DUŽINA SEČIVA	ŠIRINA	DEBLJINA	TPI	€/PAK.
71875	S 644 D	150mm	19mm	1,3mm	6	11,50

• Krstasti, set



MUST HAVE

MAXPOWER



LIST ZA SABLJASTU TESTERU, MAXPOWER,
ZA TVRDO DRVO I IVERICU, 5 KOM

ŠIFRA	BOSCH TIP	DUŽINA SEČIVA	ŠIRINA	DEBLJINA	TPI	€/PAK.
71988	S 610 DF	150mm	19mm	1,6mm	6	19,20

• Brušene, set



8% COBALT



MAXPOWER



LIST ZA SABLJASTU TESTERU, MAXPOWER,
ZA TVRDO DRVO I IVERICU, 5 KOM

ŠIFRA	BOSCH TIP	DUŽINA SEČIVA	ŠIRINA	DEBLJINA	TPI	€/PAK.
71990	S 1110 DF	230mm	19mm	1,6mm	6	26,30

• Brušene, set



8% COBALT



*KOLIČINA PRI VIŠESTRUKOJ PORUČBNI

MUST
HAVE

MAXPOWER



LIST ZA SABLJASTU TESTERU, MAXPOWER,
ZA METAL, 5 KOM



ŠIFRA	BOSCH TIP	DUŽINA SEČIVA	ŠIRINA	DEBLJINA	TPI	€ /PAK.
71880	S1122 BF	230mm	19mm	0,9mm	14	15,40

• Brušene, set



BiM
8% COBALT



MAXPOWER



LIST ZA SABLJASTU TESTERU, MAXPOWER,
ZA METAL, 5 KOM



ŠIFRA	BOSCH TIP	DUŽINA SEČIVA	ŠIRINA	DEBLJINA	TPI	€ /PAK.
71883	S1226 BEF	300mm	19mm	0,9mm	10	25,60

• Brušene, set



BiM
8% COBALT



MUST
HAVE

MAXPOWER



LIST ZA SABLJASTU TESTERU, MAXPOWER,
ZA METAL I INOKS, 5 KOM



ŠIFRA	BOSCH TIP	DUŽINA SEČIVA	ŠIRINA	DEBLJINA	TPI	€ /PAK.
71888	S922 BF	150mm	19mm	0,9mm	14	12,00

• Brušene, set



BiM
8% COBALT



MAXPOWER



LIST ZA SABLJASTU TESTERU, MAXPOWER,
ZA METAL I INOKS, 5 KOM



ŠIFRA	BOSCH TIP	DUŽINA SEČIVA	ŠIRINA	DEBLJINA	TPI	€ /PAK.
71884	S936 BEF	150mm	25mm	0,9mm	14	14,90

• Brušene, set



BiM
8% COBALT



*KOLIČINA PRI VIŠESTRUKOJ PORUDŽBINI

MAXPOWER



**LIST ZA SABLJASTU TESTERU, MAXPOWER,
ZA METAL I INOKS, 5 KOM**

ŠIFRA	BOSCH TIP	DUŽINA SEČIVA	ŠIRINA	DEBLJINA	TPI	€ /PAK.
71890	S1136 BEF	225mm	25mm	0,9mm	14	17,90

• Brušene, set



METAL

INOX

BiM
8% COBALT

MADE IN GERMANY



MATERIAL THICKNESS
3-8mm

PRECISION CUT
90°

MAXPOWER



**LIST ZA SABLJASTU TESTERU, MAXPOWER,
ZA METAL I NERĐAJUĆI METAL, 5 KOM**

ŠIFRA	BOSCH TIP	DUŽINA SEČIVA	ŠIRINA	DEBLJINA	TPI	€ /PAK.
71989	S1120 CF	230mm	19mm	1,6mm	8	26,30

• Brušene, set



METAL

Cu Al

BiM
8% COBALT

MADE IN GERMANY



MATERIAL THICKNESS
4-12mm

PRECISION CUT
90°

MAXPOWER



**LIST ZA SABLJASTU TESTERU, MAXPOWER,
ZA DRVO I METAL, 5 KOM**

ŠIFRA	BOSCH TIP	DUŽINA SEČIVA	ŠIRINA	DEBLJINA	TPI	€ /PAK.
71882	S1122 HF	230mm	19mm	0,9mm	10	15,40

• Brušene, set



WOOD

METAL

BiM
8% COBALT

MADE IN GERMANY



MATERIAL THICKNESS
3-12mm

HIGH SPEED CUT

STRAIGHT CUT

MAXPOWER



**LIST ZA SABLJASTU TESTERU, MAXPOWER,
ZA DRVO I METAL, 5 KOM**

ŠIFRA	BOSCH TIP	DUŽINA SEČIVA	ŠIRINA	DEBLJINA	TPI	€ /PAK.
71876	S1122 VF	230mm	19mm	0,9mm	10-14	15,40

• Brušene, set



WOOD

METAL

BiM
8% COBALT

MADE IN GERMANY



MATERIAL THICKNESS
3-12mm

HIGH SPEED CUT

STRAIGHT CUT

*KOLIČINA PRI VIŠESTRUKOJ PORUČBINI

MAXPOWER



MATERIAL THICKNESS
6-250mm

HIGH SPEED CUT

STRAIGHT CUT

**LIST ZA SABLJASTU TESTERU, MAXPOWER,
ZA DRVO I METAL, 5 KOM**

ŠIFRA	BOSCH TIP	DUŽINA SEČIVA	ŠIRINA	DEBLJINA	TPI	€/PAK.
71878	S1411 DF	300mm	19mm	0,9mm	6	27,90

• Brušene, set



WOOD

METAL

BiM
8% COBALT

MADE IN GERMANY



SPECIAL

NICE TO HAVE



MATERIAL THICKNESS
1-10mm

STRAIGHT CUT

**LIST ZA SABLJASTU TESTERU,
ZA GVOZDENE CEVI, ZIDNE PLOČICE I STAKLO, 2 KOM**

ŠIFRA	BOSCH TIP	DUŽINA SEČIVA	ŠIRINA	DEBLJINA	€/PAK.
71885	S 1130 RIFF	230mm	19mm	1,1mm	15,20

• Karbidna granulacija od volframa



GLASS

TILES

TCG

MADE IN EU



SPECIAL



MATERIAL THICKNESS
30-200mm

STRAIGHT CUT

**LIST ZA SABLJASTU TESTERU SPECIAL,
ZA CIGLU, 1 KOM**

ŠIFRA	BOSCH TIP	DUŽINA SEČIVA	ŠIRINA	DEBLJINA	TPI	KUTIJA	€/PAK.
71881	S 1243 HM	300mm	20mm	1,3mm	1,3	5	32,80

• Karbidni zupci od volframa



BRICK

TCT

MADE IN GERMANY



SPECIAL

MUST HAVE



STRAIGHT CUT

MATERIAL THICKNESS
<250mm

**LIST ZA SABLJASTU TESTERU SPECIAL,
ZA LED, 2 KOM**

ŠIFRA	BOSCH TIP	DUŽINA SEČIVA	ŠIRINA	DEBLJINA	TPI	€/PAK.
71877	S 1211 K	300mm	25mm	1,3mm	3	21,20

• Brušene, set



ICE

INOX

MADE IN SWITZERLAND



*KOLIČINA PRI VIŠESTRUKOJ PORUČBINI

**BEST
SELLER** **MUST
HAVE**

Karbidni zupci najboljeg kvaliteta za dugotrajnu upotrebu

Smer sečenja

KRUŽNO SEČIVO ZA CIRKULARNU TESTERU, ZA STRUČNU OBRADU DRVETA

ŠIFRA	PREČNIK	RUPU Ø	OTVORA Ø	TPI	ŠIRINA SEČENJA	POGODAN ZA	€/KOM.
71901	165mm	20mm	16,0mm	48	2,6mm	KRUŽNA TESTERA	21,00
71902	184mm	20mm	16,0mm	48	2,6mm	KRUŽNA TESTERA	22,00
71903	190mm	30mm	20,0mm	48	2,6mm	KRUŽNA TESTERA	23,00
71985	210mm	30mm	25,4mm	48	2,4mm	TESTERA ZA OBORENE IVI	27,00
71905	216mm	30mm	25,4mm	48	2,4mm	TESTERA ZA OBORENE IVI	27,00
71904	235mm	30mm	25,4mm	60	2,6mm	KRUŽNA TESTERA	33,00
71906	250mm	30mm	25,4mm	60	2,4mm	TESTERA ZA STOLOVE I OBORENE IVICE	37,00
71907	254mm	30mm	25,4mm	60	2,4mm	TESTERA ZA STOLOVE I OBORENE IVICE	37,00
71908	305mm	30mm	25,4mm	72	3,0mm	TESTERA ZA STOLOVE I OBORENE IVICE	60,00



Specijalni otvori koji obezbeđuju anti-vibraciju i smanjenje buke

Prerezi za proširenje za dodatnu stabilnsot i preciznost testere

- Teflon premazan: za brži, glatkiji i rez bez lepljenja
- Laserski rez: precizniji, čistiji i čak isečen, bez drhtanja
- Premium karbidi: za veliku trajnost i duži vek trajanja
- Pogodno za sve vrste drveta
- Pakovanje uključuje odstoynike za listove testere



**MUST
HAVE**

Karbidni zupci najboljeg kvaliteta za dugotrajnu upotrebu

Smer sečenja

KRUŽNO SEČIVO ZA CIRKULARNU TESTERU, ZA DRVO

ŠIFRA	PREČNIK	RUPU Ø	OTVORA Ø	TPI	ŠIRINA SEČENJA	POGODAN ZA	€/KOM.
71896	160mm	20mm	16,0mm	24	2,0mm	KRUŽNA TESTERA	17,00
71897	165mm	20mm	16,0mm	24	2,0mm	KRUŽNA TESTERA	17,00
71898	184mm	20mm	16,0mm	24	2,0mm	KRUŽNA TESTERA	18,00
71899	190mm	30mm	20,0mm	24	2,0mm	KRUŽNA TESTERA	19,00
71900	235mm	30mm	25,4mm	30	2,2mm	KRUŽNA TESTERA	28,00



Specijalni otvori koji obezbeđuju anti-vibraciju i smanjenje buke

Prerezi za proširenje za dodatnu stabilnsot i preciznost testere

- Teflon premazan: za brži, glatkiji i antilepljeni rez
- Laserski rez: precizniji, čistiji i čak isečen, bez drhtanja
- Premium karbidi: za veliku trajnost i duži uslužni vek
- Pogodno za građevinske drvene podloge i ostatke od betona
- Pakovanje uključuje odstoynike za listove testere



*KOLIČINA PRI VIŠESTRUKOJ PORUČBINI

MUST
HAVE

Karbidni zupci najboljeg kvaliteta
za dugotrajnu upotrebu

Prerezi za proširenje za dodatnu
stabilnost i preciznost testere



Smer sečenja

Specijalni otvori koji obezbeđuju
anti-vibraciju i smanjenje buke

KRUŽNO SEČIVO ZA CIRKULARNU TESTERU, ZA RAZNE MATERIJALE

ŠIFRA	PREČNIK	RUPU Ø	OTVORA Ø	TPI	ŠIRINA SEČENJA	POGODAN ZA	€/KOM.
71909	165mm	20mm	16,0mm	48	2,0mm	KRUŽNA TESTERA	23,00
71910	184mm	20mm	16,0mm	48	2,0mm	KRUŽNA TESTERA	24,00
71911	190mm	30mm	20,0mm	54	2,0mm	KRUŽNA TESTERA	26,00
71913	216mm	30mm	25,4mm	64	2,4mm	TESTERA ZA OBORENE IVI	39,00
71912	235mm	30mm	25,4mm	64	2,4mm	KRUŽNA TESTERA	47,00
71914	250mm	30mm	25,4mm	80	2,4mm	TESTERA ZA STOLOVE I OBORENE IVICE	49,00
71915	254mm	30mm	25,4mm	80	2,4mm	TESTERA ZA STOLOVE I OBORENE IVICE	49,00
71916	305mm	30mm	25,4mm	96	2,4mm	TESTERA ZA STOLOVE I OBORENE IVICE	62,00

- Teflon premazan: za brži, glatkiji i antilepljeni rez
- Laserski rez: precizniji, čistiji i čak isečen, bez drhtanja
- Premium karbidi: za veliku trajnost i duži uslužni vek
- Pogodno za laki metal, aluminijum, plastiku, epoksid i drvo
- Pakovanje uključuje odstojnike za listove testere



Karbidni zupci najboljeg kvaliteta za dugotrajnu
upotrebu

Smer sečenja



*KOLIČINA PRI VIŠESTRUKOJ PORUČBINI

Prerezi za proširenje za dodatnu
stabilnost i preciznost testere

Specijalni otvori koji obezbeđuju
anti-vibraciju i smanjenje buke

KRUŽNO SEČIVO ZA CIRKULARNU TESTERU, ZA ALUMINIJUM

ŠIFRA	PREČNIK	RUPU Ø	OTVORA Ø	TPI	ŠIRINA SEČENJA	POGODAN ZA	€/KOM.
71919	190mm	30mm	20,0mm	56	2,6mm	KRUŽNA TESTERA	29,00
71921	216mm	30mm	25,4mm	64	2,6mm	TESTERA ZA OBORENE IVI	40,00
71922	250mm	30mm	25,4mm	80	2,8mm	TESTERA ZA STOLOVE I OBORENE IVICE	53,00
71923	254mm	30mm	25,4mm	80	2,8mm	TESTERA ZA STOLOVE I OBORENE IVICE	54,00
71924	305mm	30mm	25,4mm	96	2,8mm	TESTERA ZA STOLOVE I OBORENE IVICE	67,00

- Teflon premazan: za brži, glatkiji i antilepljeni rez
- Laserski rez: precizniji, čistiji i čak isečen, bez drhtanja
- Premium karbidi: za veliku trajnost i duži uslužni vek
- Pogodno za lake metale, kao što je aluminijum
- Pakovanje uključuje odstojnike za listove testere



GRAFIKON ZA SPECIFIKACIJU

Proizvoda	Laser univerzalni	Čist rez pločice	Clean Cut keramika	Čist rez univerzalni	Mermer	Segmentirani univerzalni	Pločice	Čist rez univerzalni
	★★★ BEST	★★★ BEST	★★★ BEST	★★★ BEST	★★★ BEST	★ STANDARD	★ STANDARD	★ STANDARD
	115/125/180/230	115/125	115/125/180/230	115/125/180/230	115/125/230	115/125/180/230	115/125/180/230	115/125/180/230
Keramika		■	■	□			■	
Porcelanske pločice		■	□				■	
Granitne pločice		■	■				□	
Kamen	■			■		■		■
Beton	■			■		■		■
Armirani beton	■			□		□		□
Mermer					■			
Granit		□	■	□				

OBJAŠNJENJA: ★★★ MAXPOWER (visoka efikasnost) ★ CLASSIC (standardna efikasnost) ■ ISKRENO PREPORUČENO □ PREPORUČENO



**BEST
SELLER** **MUST
HAVE**



- Pogodan za pločice, keramiku i granit
- Velika brzina sečenja
- Preciznost
- Za suve ili vlažne površine
- Vazduh-hlađenje
- Najbrži i najizdržljiviji disk za keramiku na svetu
- Veća stabilnost zbog zamaha

MAXPOWER

**DIJAMANTSKI DISK
ZA SEČENJE MAXPOWER,
TURBO CUT KERAMIČKI**

ŠIFRA	PREČNIK	DEBLJINA	DIMENZIJE ZUBE	RUPU Ø	KUTIJA	€/KOM.
74494	115mm	1,2mm	7mm	22,2mm	10	14,00
74495	125mm	1,2mm	7mm	22,2mm	10	15,50
74497	230mm	1,8mm	7mm	22,2mm	5	37,00



**MUST
HAVE**



MAXPOWER

**DIJAMANTSKI DISK
ZA SEČENJE MAXPOWER MERMERA**

ŠIFRA	PREČNIK	DEBLJINA	DIMENZIJE ZUBE	RUPU Ø	KUTIJA	€/KOM.
74470	115mm	2,0mm	7mm	22,2mm	10	29,00
74471	125mm	2,0mm	7mm	22,2mm	10	35,00
74473	230mm	2,6mm	7mm	22,2mm	6	66,00



*KOLIČINA PRI VIŠESTRUKOJ PORUDŽBINI



MAXPOWER

ČISTO SEČENJE ZA PLOČICE

DIJAMANTSKI DISK ZA SEČENJE MAXPOWER

ŠIFRA	PREČNIK	DEBLJINA	DIMENZIJE ZUBE	RUPU Ø	KUTIJA	€/KOM.
74298	115mm	1,4mm	7mm	22,2mm	10	13,00
74299	125mm	1,4mm	7mm	22,2mm	10	14,00

- Pogodan za pločice, porcelan i granit
- Velika brzina sečenja
- Preciznost
- Za suve i vlažne površine
- Automatsko hlađenje





GRANITE

BEST SELLER



MAXPOWER

BRZO I ČISTO SEČENJE

DIJAMANTSKI DISK ZA SEČENJE MAXPOWER, ČIST REZ, UNIVERZALNI

ŠIFRA	PREČNIK	DEBLJINA	DIMENZIJE ZUBE	RUPU Ø	KUTIJA	€/KOM.
74490	115mm	2,0mm	12mm	22,2mm	10	21,00
74491	125mm	2,0mm	12mm	22,2mm	10	24,00
74493	230mm	2,6mm	12mm	22,2mm	5	55,00

- Pogodno za beton, tvrd kamen, građevinske materijale, kamen
- Velika brzina sečenja
- Preciznost
- Za suve i vlažne površine
- Automatsko hlađenje





BEST SELLER

MUST HAVE



MAXPOWER

NAJVEĆA IZDRŽLJIVOST NA SVETU

DIJAMANTSKI DISK ZA SEČENJE MAXPOWER, LASERSKI, UNIVERZALNI

ŠIFRA	PREČNIK	DEBLJINA	DIMENZIJE ZUBE	RUPU Ø	KUTIJA	€/KOM.
74486	115mm	2,4mm	10mm	22,2mm	10	27,00
74487	125mm	2,4mm	10mm	22,2mm	10	31,00
74488	180mm	2,6mm	10mm	22,2mm	10	53,00
74489	230mm	2,6mm	10mm	22,2mm	5	66,00

- Pogodno za beton, tvrd kamen, građevinske materijale
- Velika brzina sečenja
- Preciznost
- Za suve i vlažne površine
- Automatsko hlađenje





**BEST
SELLER** **MUST
HAVE**



CLASSIC

**BRZO I ČISTO
SEČENJE PLOČICA**

**DIJAMANTSKI DISK
ZA SEČENJE KERAMIČKIH PLOČICA, KLASIČNI**

ŠIFRA	PREČNIK	DEBLJINA	DIMENZIJE ZUBE	RUPE Ø	KUTIJA	€/KOM.
74484	115mm	1,8mm	10mm	22,2mm	10	6,60
74485	125mm	1,8mm	10mm	22,2mm	10	7,50
74254	180mm	2,2mm	10mm	22,2mm	10	17,00
74255	230mm	2,4mm	10mm	22,2mm	5	21,00



- Pogodan za pločice, porcelan
- Za brzo i pouzdano sečenje
- Za suve i vlažne površine
- Veća stabilnost zbog zamaha



CLASSIC

**ČISTO SEČENJE
ZA UNIVERZALNU UPOTREBU**

**DIJAMANTSKI DISK
ZA SEČENJE, UNIVERZALNI, KLASIČNI**

ŠIFRA	PREČNIK	DEBLJINA	DIMENZIJE ZUBE	RUPE Ø	KUTIJA	€/KOM.
74482	115mm	2,2mm	10mm	22,2mm	10	9,00
74483	125mm	2,2mm	10mm	22,2mm	10	10,00
74249	230mm	2,8mm	10mm	22,2mm	5	27,00



- Pogodno za tvrd kamen, beton i građevinske materijale
- Za brzo i pouzdano sečenje
- Za suve i vlažne površine
- Veća stabilnost zbog zamaha

**BEST
SELLER** **MUST
HAVE**



CLASSIC

**SEGMENTIRANI
ZA UNIVERZALNU UPOTREBU**

**DIJAMANTSKI DISK
ZA SEČENJE, UNIVERZALNI, KLASIČNI**

ŠIFRA	PREČNIK	DEBLJINA	DIMENZIJE ZUBE	RUPE Ø	KUTIJA	€/KOM.
74480	115mm	2,4mm	10mm	22,2mm	10	11,00
74481	125mm	2,4mm	10mm	22,2mm	10	12,50
74247	230mm	2,6mm	10mm	22,2mm	5	30,00



- Pogodno za tvrd kamen, beton i građevinske materijale
- Za brzo i pouzdano sečenje
- Za suve i vlažne površine
- Veća stabilnost zbog zamaha

*KOLIČINA PRI VIŠESTRUKOJ PORUDŽBINI

NEW



FE/S/CI < 0,1%

TOPCUT

DISK ZA SEČENJE
ZA INOKS TOP CUT

ŠIFRA	PREČNIK	DEBLJINA	KUTIJA	€/KOM.
72578	115mm	1,0mm	25*	1,60
72579	125mm	1,0mm	25*	1,70

- Čisti i brzi rezovi
- 2 puta veća izdržljivost
- Disk za brušenje visokog kvaliteta sa VSM ZIRCONIA ALUMINA materijalom za brušenje
- Potvrda EN 12413



BEST SELLER MUST HAVE



FE/S/CI < 0,1%

MAXPOWER

DISK ZA SEČENJE
ZA INOKS MAXPOWER

ŠIFRA	PREČNIK	DEBLJINA	KUTIJA	€/KOM.
74260	115mm	1,0mm	25*	1,80
74261	125mm	1,0mm	25*	1,90
74262	180mm	1,6mm	25*	3,00
74263	230mm	2,0mm	25*	4,00

- Kompozitno ojačanje
- 2 do 3 puta veća izdržljivost
- Disk za brušenje visokog kvaliteta sa VSM ZIRCONIA ALUMINA materijalom za brušenje
- Potvrda EN 12413



FE/S/CI < 0,1%

MAXPOWER

DISK ZA SEČENJE
ZA ČELIK I INOKS MAXPOWER

ŠIFRA	PREČNIK	DEBLJINA	KUTIJA	€/KOM.
74498	115mm	1,2mm	25*	1,10
74499	125mm	1,2mm	25*	1,20

- Potvrda EN 12413



FE/S/CI < 0,1%

Professional Series

DISK ZA SEČENJE
ZA INOKS PROFESSIONAL SERIES

ŠIFRA	PREČNIK	DEBLJINA	KUTIJA	€/KOM.
74264	115mm	1,0mm	25*	1,10
74265	125mm	1,0mm	25*	1,20
74296	180mm	2,0mm	25*	2,70
74297	230mm	2,0mm	25*	3,00

- Kompozitno ojačanje
- 30% veća izdržljivost
- Potvrda EN 12413



*KOLIČINA PRI VIŠESTRUKOJ PORUDŽBINI

MUST TRY



FE/S/CI < 0,1%

MAXPOWER

**DISK ZA SEČENJE
MAXPOWER ZA ČELIK I INOKS**

ŠIFRA	PREČNIK	DEBLJINA	KUTIJA	€/KOM.
74270	115mm	1,6mm	25*	1,20
74271	125mm	1,6mm	25*	1,30
74272	180mm	2,5mm	25*	2,90
74273	230mm	2,5mm	25*	3,50

• Potvrda EN 12413

EASY CUT
TECHNOLOGY

LONG LIFE



BEST SELLER MUST HAVE



FE/S/CI < 0,1%

Professional Series

**DISK ZA SEČENJE
SERIJA ZA ČELIK PROFESSIONAL SERIES**

ŠIFRA	PREČNIK	DEBLJINA	KUTIJA	€/KOM.
74274	115mm	2,5mm	25*	1,40
74275	125mm	2,5mm	25*	1,50
74276	180mm	3,0mm	25*	3,00
74277	230mm	3,0mm	25*	3,60

• Potvrda EN 12413



FE/S/CI < 0,1%

Professional Series

**DISK ZA SEČENJE ČELIČNI
SA PRESOVANIM CENTROM PROFESSIONAL SERIES**

ŠIFRA	PREČNIK	DEBLJINA	KUTIJA	€/KOM.
74278	115mm	2,5mm	25*	1,40
74279	125mm	2,5mm	25*	1,50
74281	230mm	3,0mm	25*	3,60

• Potvrda EN 12413



NEW



Professional Series

**DISK ZA SEČENJE
SERIJA ZA ČELIK PROFESSIONAL SERIES**

ŠIFRA	PREČNIK	DEBLJINA	KUTIJA	€/KOM.
71991	355mm	4,2mm	25*	11,00

• Potvrda EN 12413



*KOLIČINA PRI VIŠESTRUKOJ PORUDŽBINI

BEST SELLER **MUST HAVE**



EN 12413
S⁺

13405

Art. No. 74 290

max 13.300 RPM
80 m/s

Stain
Plaster
Kamen
Плиты

C 30 V-BF
115 x 3,2 x 22,23
MADE IN ITALY

STONE

Professional Series

**DISK ZA SEČENJE
ZA MERMER PROFESSIONAL SERIES**

ŠIFRA	PREČNIK	DEBLJINA	KUTIJA	€/KOM.
74290	115mm	3,2mm	25*	1,50
74291	125mm	3,2mm	25*	1,60
74292	180mm	3,2mm	25*	3,40
74293	230mm	3,2mm	25*	4,10

MADE IN ITALY

MUST HAVE



EN 12413
S⁺

13476

Art. No. 74 266

max 13.300 RPM
80 m/s

Stain
Plaster
Stone
Плиты

115 x 3,2 x 22,3
C 46 V-BF
MADE IN ITALY

STONE

Professional Series

**DISK ZA SEČENJE
ZA MERMER PROFESSIONAL SERIES**

ŠIFRA	PREČNIK	DEBLJINA	KUTIJA	€/KOM.
74266	115mm	2,0mm	25*	1,40
74267	125mm	2,0mm	25*	1,50
74268	180mm	2,5mm	25*	3,20
74269	230mm	2,5mm	25*	3,50

MADE IN ITALY

MUST HAVE



EN 12413
S⁺

13405

Art. No. 74 282

max 13.300 RPM
80 m/s

Stahl
Acier
Чугун

A 24R S-BF
115 x 6,5 x 22,23
MADE IN ITALY

STEEL

Professional Series

**BRUSNI DISK SA PRESOVANIM CENTROM
PROFESSIONAL SERIES**

ŠIFRA	PREČNIK	DEBLJINA	KUTIJA	€/KOM.
74282	115mm	6,5mm	10*	2,10
74283	125mm	6,5mm	10*	2,30
74284	180mm	6,5mm	10*	4,70
74285	230mm	6,5mm	10*	6,10

MADE IN ITALY

*KOLIČINA PRI VIŠESTRUKOJ PORUČBINI

**MUST
HAVE**

**POLUFELKSIBILNI DISK
ZA BRUŠENJE 115mm**

ŠIFRA	GRANUL.	KUTIJA	€ /KOM.
19874	24	10*	2,10
19875	36	10*	2,10
19876	40	10*	2,10
19877	60	10*	2,10
19878	80	10*	2,10
19880	100	10*	2,10
19879	120	10*	2,10
24449	150	10*	2,10

- Pogodan za brušenje betona
- Sa slojem vlakana teško tipa i višestrukim slojevima specijalnog brusnog materijala, slepljenog smolom
- Dug vek trajanja

**MUST
HAVE**

**POLUFELKSIBILNI DISK
ZA BRUŠENJE 125mm**

ŠIFRA	GRANUL.	KUTIJA	€ /KOM.
19881	24	10*	2,30
19882	36	10*	2,30
19883	40	10*	2,30
19884	60	10*	2,30
19885	80	10*	2,30
19886	100	10*	2,30
19887	120	10*	2,30

- Pogodan za brušenje betona
- Sa slojem vlakana teško tipa i višestrukim slojevima specijalnog brusnog materijala, slepljenog smolom
- Dug vek trajanja

**MUST
HAVE**

**POLUFELKSIBILNI DISK
ZA BRUŠENJE 180mm**

ŠIFRA	GRANUL.	KUTIJA	€ /KOM.
19895	24	10*	3,20
19896	36	10*	3,20
19897	40	10*	3,20
19898	60	10*	3,20
19899	80	10*	3,20
19900	100	10*	3,20
19901	120	10*	3,20

- Pogodan za brušenje betona
- Sa slojem vlakana teško tipa i višestrukim slojevima specijalnog brusnog materijala, slepljenog smolom
- Dug vek trajanja



*KOLIČINA PRI VIŠESTRUKOJ PORUČBINI

MUST TRY

Kurba



Zakrivljeno

MAXPOWER

2x
MORE
DURABLE

2x
FASTER

**MAXPOWER
LAMELNI DISK,
KERAMIČKI 115mm**

ŠIFRA	GRAN-UL.	KUTIJA	€/KOM.
74370	36	10*	3,80
74371	40	10*	3,80
74372	60	10*	3,80
74373	80	10*	3,80
74375	120	10*	3,80

• Ulegnut tip



MADE IN EU



MUST TRY

Kurba



Zakrivljeno

MAXPOWER

2x
MORE
DURABLE

2x
FASTER

**MAXPOWER
LAMELNI DISK,
KERAMIČKI 125mm**

ŠIFRA	GRAN-UL.	KUTIJA	€/KOM.
74377	36	10*	4,30
74378	40	10*	4,30
74379	60	10*	4,30
74380	80	10*	4,30
74382	120	10*	4,30

• Ulegnut tip



MADE IN EU



BEST SELLER

MUST HAVE

Kurba



Zakrivljeno

Standard Line

**STANDARD LINE
LAMELNI DISK
SA CIRKON 115mm**

ŠIFRA	GRAN-UL.	KUTIJA	€/KOM.
74831	24	10*	2,40
74832	36	10*	2,40
74833	40	10*	2,40
74834	60	10*	2,40
74835	80	10*	2,40
74836	100	10*	2,40
74837	120	10*	2,40

• Ulegnut tip



MADE IN EU



BEST SELLER

MUST HAVE

Kurba



Zakrivljeno

Standard Line

**STANDARD LINE
LAMELNI DISK
SA CIRKON 125mm**

ŠIFRA	GRAN-UL.	KUTIJA	€/KOM.
74838	24	10*	2,80
74839	36	10*	2,80
74840	40	10*	2,80
74841	60	10*	2,80
74842	80	10*	2,80
74843	100	10*	2,80
74844	120	10*	2,80

• Ulegnut tip



MADE IN EU



*KOLIČINA PRI VIŠESTRUKOJ PORUČBINI

Kurba

Zakrivljeno

Professional Series

**PROFESSIONAL SERIES
LAMELNI DISK
SA CIRKON 115mm**

ŠIFRA	GRAN-UL.	KUTIJA	€ /KOM.
19939	24	10*	3,00
19940	36	10*	3,00
19941	40	10*	3,00
19942	60	10*	3,00
19943	80	10*	3,00
19944	100	10*	3,00
19945	120	10*	3,00

• Ulegnut tip

**+60%
MORE
DURABLE**

**+60%
FASTER**

INOX
STEEL

MADE IN EU

Kurba

Zakrivljeno

Professional Series

**PROFESSIONAL SERIES
LAMELNI DISK
SA CIRKON 125mm**

ŠIFRA	GRAN-UL.	KUTIJA	€ /KOM.
19946	24	10*	3,50
19947	36	10*	3,50
19948	40	10*	3,50
19949	60	10*	3,50
19950	80	10*	3,50
19951	100	10*	3,50
19952	120	10*	3,50

• Ulegnut tip

**+60%
MORE
DURABLE**

**+60%
FASTER**

INOX
STEEL

MADE IN EU

Kurba

Zakrivljeno

Professional Series

**PROFESSIONAL SERIES
LAMELNI DISK
SA CIRKON 180mm**

ŠIFRA	GRAN-UL.	KUTIJA	€ /KOM.
19954	36	10*	6,70
19955	40	10*	6,70
19956	60	10*	6,70
19957	80	10*	6,70
19958	100	10*	6,70
19959	120	10*	6,70

• Ulegnut tip

**+60%
MORE
DURABLE**

**+60%
FASTER**

INOX
STEEL

MADE IN EU

MUST HAVE

Kurba

Pravi

TURBO PRO

**TURBO PRO LAMELNI DISK
SA CIRKON 115mm
SA PLASTIČNA OSNOVA**

ŠIFRA	GRAN-UL.	KUTIJA	€ /KOM.
21050	24	10*	3,00
21051	36	10*	3,00
21052	40	10*	3,00
21053	60	10*	3,00
21054	80	10*	3,00
21055	100	10*	3,00
21056	120	10*	3,00

**2x
MORE
DURABLE**

**2x
FASTER**

INOX
STEEL

*KOLIČINA PRI VIŠESTRUKOJ PORUČBINI

NEW

Zakrivljeno



NETKANI ABRAZIVNI DISK, 115mm

ŠIFRA	PREČNIK	TIP	MAX RPM	BOJA	KUTIJA	€/KOM.
72095	115mm	KRUPNA	13.300min ⁻¹	BRAON	10*	5,00
72096	115mm	SREDNJA	13.300min ⁻¹	CRVENO	10*	5,00
72097	115mm	SITNA	13.300min ⁻¹	PLAVO	10*	5,00

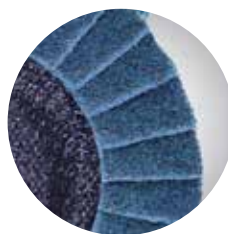

- Kombinuje ravnanje ivica i poliranje u jednom koraku radi veće efikasnosti
- Napravljeno tako da bude dugotrajno, fleksibilno i otporno na toplotu
- Odličan izbor za aluminijum, čelik i supstrate inoksa
- Krilca koja se preklapaju povećavaju izdržljivost i unapređuju brzinu sečenja

NEW NICE TO HAVE

Zakrivljeno



NETKANI ABRAZIVNI DISK, 125mm

ŠIFRA	PREČNIK	TIP	MAX RPM	BOJA	KUTIJA	€/KOM.
72098	125mm	KRUPNA	12.200min ⁻¹	BRAON	10*	6,00
72099	125mm	SREDNJA	12.200min ⁻¹	CRVENO	10*	6,00
72100	125mm	SITNA	12.200min ⁻¹	PLAVO	10*	6,00

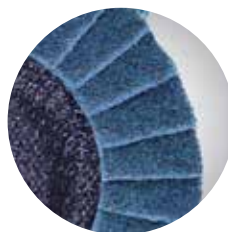

- Kombinuje ravnanje ivica i poliranje u jednom koraku radi veće efikasnosti
- Napravljeno tako da bude dugotrajno, fleksibilno i otporno na toplotu
- Odličan izbor za aluminijum, čelik i supstrate inoksa
- Krilca koja se preklapaju povećavaju izdržljivost i unapređuju brzinu sečenja

*KOLIČINA PRI VIŠESTRUKOJ PORUČBINI

NEW



DISK ZA ČIŠĆENJE 115mm

ŠIFRA	PREČNIK	TIP	MAX RPM	BOJA	KUTIJA	€/KOM.
72101	115mm	VRLO KRUPNA	10.000min ⁻¹	CRNO	10*	12,40

- Brzo uklanja rđu, boju i premaze sa metala
- Velika brzina, slabe vibracije i malo varničenja
- Sa posebnim sastavom koji je otporan na začepljenja i pruža dugotrajnost i unapređenu brzinu sečenja

NEW NICE TO HAVE



DISK ZA ČIŠĆENJE 125mm

ŠIFRA	PREČNIK	TIP	MAX RPM	BOJA	KUTIJA	€/KOM.
72102	125mm	VRLO KRUPNA	9.000min ⁻¹	CRNO	10*	13,40

- Brzo uklanja rđu, boju i premaze sa metala
- Velika brzina, slabe vibracije i malo varničenja
- Sa posebnim sastavom koji je otporan na začepljenja i pruža dugotrajnost i unapređenu brzinu sečenja

NEW



DISK ZA ŠMIRGLANJE, 150mm

ŠIFRA	DEBLJINA	PREČNIK	TIP	KUTIJA	€/KOM.
72278	6mm	150mm	SREDNJA	10	25,00
72279	6mm	150mm	KRUPNA	10	25,00
72280	3mm	150mm	SREDNJA	10	25,00
72281	3mm	150mm	KRUPNA	10	25,00

- Za nerđajući čelik, metal i druge materijale
- U 2 različita tipa: grubi disk za šmirglanje se koristi za brušenje, medijum za završnu obradu ili poliranje
- Pogodan za brusilicu za brušenje spoljašnjih varova



NEW

ZIRCONIA
ALUMINA



BRUSNA TRAKA
533mmx4mm, 10 KOM

ŠIFRA	DUŽINA	ŠIRINA	GRANUL.	KUTIJA	€/PAK.
72291	533mm	4mm	60	10	10,40
72292	533mm	4mm	80	10	9,80
72293	533mm	4mm	120	10	9,50
72294	533mm	4mm	180	10	9,50
72295	533mm	4mm	240	10	9,50

- Visokokvalitetna brusna traka, sa velikim životnim vekom
- Visok učinak u srednjoj i krupnoj granulaciji, za površine od aluminijuma, nerđajućeg čelika i čelika
- Pogodno za trakastu brusilicu za cevi



NEW

ZIRCONIA
ALUMINA



BRUSNA TRAKA
533mmx9mm, 10 KOM

ŠIFRA	DUŽINA	ŠIRINA	GRANUL.	KUTIJA	€/PAK.
72296	533mm	9mm	40	10	12,00
72297	533mm	9mm	60	10	11,50
72298	533mm	9mm	80	10	11,00
72299	533mm	9mm	120	10	11,00
72300	533mm	9mm	180	10	11,00
72301	533mm	9mm	240	10	11,00

- Visokokvalitetna brusna traka, sa velikim životnim vekom
- Visok učinak u srednjoj i krupnoj granulaciji, za površine od aluminijuma, nerđajućeg čelika i čelika
- Pogodno za trakastu brusilicu za cevi



NEW

ZIRCONIA
ALUMINA



BRUSNA TRAKA
533mmx30mm, 10 KOM

ŠIFRA	DUŽINA	ŠIRINA	GRANUL.	KUTIJA	€/PAK.
72304	533mm	30mm	40	10	19,00
72305	533mm	30mm	60	10	15,00
72306	533mm	30mm	80	10	14,00
72307	533mm	30mm	120	10	13,00
72308	533mm	30mm	180	10	13,00
72309	533mm	30mm	240	10	13,00

- Visokokvalitetna brusna traka, sa velikim životnim vekom
- Visok učinak u srednjoj i krupnoj granulaciji, za površine od aluminijuma, nerđajućeg čelika i čelika
- Pogodno za trakastu brusilicu za cevi



NEW

ZIRCONIA
ALUMINA



BRUSNA TRAKA
760mmx40mm, 10 KOM

ŠIFRA	DUŽINA	ŠIRINA	GRANUL.	KUTIJA	€/PAK.
72312	760mm	40mm	40	10	26,00
72313	760mm	40mm	60	10	21,00
72314	760mm	40mm	80	10	20,00
72315	760mm	40mm	120	10	18,00
72316	760mm	40mm	180	10	18,00
72317	760mm	40mm	240	10	18,00

- Visokokvalitetna brusna traka, sa velikim životnim vekom
- Visok učinak u srednjoj i krupnoj granulaciji, za površine od aluminijuma, nerđajućeg čelika i čelika
- Pogodno za trakastu brusilicu za cevi

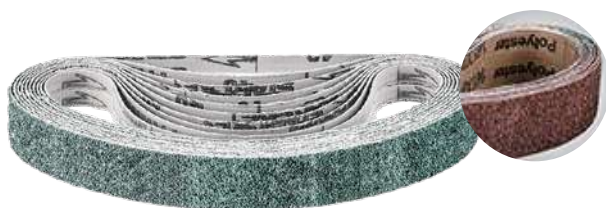

*KOLIČINA PRI VIŠESTRUKOJ PORUDŽBINI

NEW

BRUSNA TRAKA, SCOTCH-BRITE TIP
533mmx9mm, 3 KOM

ŠIFRA	DUŽINA	ŠIRINA	GRANUL.	BOJA	KUTIJA	€/PAK.
72303	533mm	9mm	120	CRVENO	34	7,00
72302	533mm	9mm	320	ZELENO	34	7,00

- Za uklanjanje manjih oštećenja, ogrebotina, mrlja, rđe i prljavštine
- Za brušenje, čišćenje i završnu obradu nerđajućeg čelika, legura titanijuma, lakih metala, obojenih metala i plastike
- Pogodno za trakastu brusilicu za cevi

NEW

BRUSNA TRAKA, SCOTCH-BRITE TIP
533mmx30mm, 3 KOM

ŠIFRA	DUŽINA	ŠIRINA	GRANUL.	BOJA	KUTIJA	€/PAK.
72311	533mm	30mm	120	CRVENO	34	17,00
72310	533mm	30mm	320	ZELENO	34	17,00

- Za uklanjanje manjih oštećenja, ogrebotina, mrlja, rđe i prljavštine
- Za brušenje, čišćenje i završnu obradu nerđajućeg čelika, legura titanijuma, lakih metala, obojenih metala i plastike
- Pogodno za trakastu brusilicu za cevi

NEW

BRUSNA TRAKA, SCOTCH-BRITE TIP
760mmx40mm, 3 KOM

ŠIFRA	DUŽINA	ŠIRINA	GRANUL.	BOJA	KUTIJA	€/PAK.
72319	760mm	40mm	120	CRVENO	34	31,00
72318	760mm	40mm	320	ZELENO	34	31,00

- Za uklanjanje manjih oštećenja, ogrebotina, mrlja, rđe i prljavštine
- Za brušenje, čišćenje i završnu obradu nerđajućeg čelika, legura titanijuma, lakih metala, obojenih metala i plastike
- Pogodno za trakastu brusilicu za cevi

NEW
**ALUMINIUM
OXIDE**

BRUSNA TRAKA, CRVENI
533mmx75mm, 3 KOM

ŠIFRA	DUŽINA	ŠIRINA	GRANUL.	KUTIJA	€/PAK.
72320	533mm	75mm	40	34	8,40
72321	533mm	75mm	60	34	7,80
72322	533mm	75mm	80	34	7,50
72323	533mm	75mm	100	34	7,20
72324	533mm	75mm	120	34	7,20
72325	533mm	75mm	150	34	7,20
72326	533mm	75mm	180	34	7,20
72327	533mm	75mm	240	34	7,20



- Za brušenje, čišćenje i završnu obradu nerđajućeg čelika, legura titanijuma, lakih metala, obojenih metala i plastike
- Pogodno za trakastu brusilicu



NEW



**BRUSNA TRAKA,
915x100mm, 3 KOM**

ALUMINIUM
OXIDE

ŠIFRA	PREČNIK	ŠIRINA	GRANUL.	KUTIJA	€/PAK.
72529	915mm	100mm	60	34	16,00
72532	915mm	100mm	80	34	16,00
72534	915mm	100mm	100	34	16,00



- Za brušenje, čišćenje i završnu obradu nerđajućeg čelika, legura titanijuma, lakih metala, obojenih metala i plastike
- Pogodno za stone trakaste brusilice



NEW



**BRUSNA TRAKA,
686x50mm, 3 KOM**

ALUMINIUM
OXIDE

ŠIFRA	PREČNIK	ŠIRINA	GRANUL.	KUTIJA	€/PAK.
72535	686mm	50mm	60	34	7,40
72536	686mm	50mm	80	34	7,40
72538	686mm	50mm	100	34	7,40



- Za brušenje, čišćenje i završnu obradu nerđajućeg čelika, legura titanijuma, lakih metala, obojenih metala i plastike
- Pogodna za kombinovane brusilice sa točkom i remen-brusilicu



NEW



**BRUSNI VALJAK, SCOTCH-BRITE TIP,
100x100mm, 2 KOM**

ŠIFRA	PREČNIK	ŠIRINA	GRANUL.	BOJA	KUTIJA	€/PAK.
72290	100mm	100mm	60	BRAON	50	22,00
72289	100mm	100mm	120	CRVENO	50	22,00
72288	100mm	100mm	320	ZELENO	50	22,00



- Za uklanjanje manjih oštećenja, ogrebotina, mrlja, rđe i prljavštine
- Za brušenje, čišćenje i završnu obradu nerđajućeg čelika, legura titanijuma, lakih metala, obojenih metala i plastike
- Pogodno za mašinu matiranje



NEW



**BRUSNI VALJAK,
100x100mm, 10 KOM**

ZIRCONIA
ALUMINA

ŠIFRA	PREČNIK	ŠIRINA	GRANUL.	€/PAK.
72282	100mm	100mm	40	33,00
72283	100mm	100mm	60	29,00
72284	100mm	100mm	80	27,00
72285	100mm	100mm	120	24,00
72286	100mm	100mm	180	24,00
72287	100mm	100mm	240	24,00



- Visokokvalitetna brusna traka dugog životnog veka
- Visoki učinak u srednjim i krupnim granulacijama, za aluminijumske površine, nerđajući čelik i čelik
- Pogodno za mašinu matiranje



*KOLIČINA PRI VIŠESTRUKOJ PORUČBINI

NEW

BRUSNI VALJAK OD PLATNA SA OTVOROM ZA KLJUČ

ŠIFRA	PREČNIK	VISINA	RUPE Ø	GRANUL.	MAX RPM	KUTIJA	€/KOM.
72080	100mm	100mm	19mm	40	5.700min ⁻¹	5	30,00
72081	100mm	100mm	19mm	60	5.700min ⁻¹	5	30,00
72082	100mm	100mm	19mm	80	5.700min ⁻¹	5	30,00
72083	100mm	100mm	19mm	120	5.700min ⁻¹	5	30,00
72084	100mm	100mm	19mm	180	5.700min ⁻¹	5	30,00

 5.700
RPM

- Za uklanjanje farbe, šmirglanje i jako brušenje
- Uklanja ogrebotine, rđu, staru farbu i grube ivice
- Primena 40 zrna omogućava uklanjanje čak i dubokih ogrebotina na nerđajućem čeliku

NEW

**NETKANI BRUSNI VALJAK
SA OTVOROM ZA KLJUČ**

ŠIFRA	PREČNIK	VISINA	RUPE Ø	GRANUL.	TIP	MAX RPM	KUTIJA	€/KOM.
72085	100mm	100mm	19mm	80	KRUPNA	5.700min ⁻¹	5	16,00
72086	100mm	100mm	19mm	180	SREDNJA	5.700min ⁻¹	5	16,00
72087	100mm	100mm	19mm	280	SITNA	5.700min ⁻¹	5	16,00
72088	100mm	100mm	19mm	320	VRLO SITNA	5.700min ⁻¹	5	16,00

 5.700
RPM

- Za efikasno poliranje površina nerđajućeg čelika, bakra, aluminijuma, mesinga itd.

NEW

**KOMBINOVANI BRUSNI VALJAK
SA OTVOROM ZA KLJUČ**

ŠIFRA	PREČNIK	VISINA	RUPE Ø	GRANUL.	TIP	MAX RPM	KUTIJA	€/KOM.
72089	100mm	100mm	19mm	80	KRUPNA	5.700min ⁻¹	5	18,00
72090	100mm	100mm	19mm	180	SREDNJA	5.700min ⁻¹	5	18,00
72091	100mm	100mm	19mm	280	SITNA	5.700min ⁻¹	5	18,00
72092	100mm	100mm	19mm	320	VRLO SITNA	5.700min ⁻¹	5	18,00

 5.700
RPM

- Pogodno za ravnanje i poliranje.
- Uklanja manje ogrebotine na metalu, tvrdoj plastici i drvetu

NEW

 5.700
RPM

**FILCANI BRUSNI VALJAK
SA OTVOROM ZA KLJUČ**

ŠIFRA	PREČNIK	VISINA	RUPE Ø	MAX RPM	KUTIJA	€/KOM.
72093	100mm	100mm	19mm	5.700min ⁻¹	5	35,00

- Pogodno za upotrebu na metalu, plastici i fiberglasu
- Izdržljiv, dugotrajan

NEW

 5.700
RPM

**BRUSNI VALJAK SA OTVOROM ZA KLJUČ
SA TRAKOM ZA ČIŠĆENJE**

ŠIFRA	PREČNIK	VISINA	RUPE Ø	MAX RPM	KUTIJA	€/KOM.
72094	100mm	100mm	19mm	5.700min ⁻¹	5	50,00

- Pogodan za uklanjanje masnoće, za čišćenje zavarenih spojeva i intenzivno uklanjanje rđe i oksidacionih slojeva u dubini

NEW

- Za brušenje, pruža veliku fleksibilnost i odlične mogućnosti završne obrade
- Nudi agresivniji rez, sposoban da ukloniti nesavršenosti i površinske ožiljke
- Idealno za brušenje sitnih delova i odlivaka, unutrašnjih površina u cevima, delovima i nepristupačnim segmentima
- Pogodno za upotrebu na ravnoj brusilici
- Prečnik osovine 6mm

BRUSNI VALJAK
SA OSOVINOM, PLATNO

ŠIFRA	PREČNIK	VISINA	GRANUL.	MAX RPM	KUTIJA	€/KOM.
72039	30mm	15mm	40	25.400min ⁻¹	10*	1,30
72040	30mm	15mm	60	25.400min ⁻¹	10*	1,30
72041	30mm	15mm	80	25.400min ⁻¹	10*	1,30
72042	30mm	15mm	120	25.400min ⁻¹	10*	1,30
72043	40mm	20mm	40	19.100min ⁻¹	10*	1,60
72044	40mm	20mm	60	19.100min ⁻¹	10*	1,60
72045	40mm	20mm	80	19.100min ⁻¹	10*	1,60
72046	40mm	20mm	120	19.100min ⁻¹	10*	1,60
72047	50mm	30mm	40	15.300min ⁻¹	10*	2,30
72048	50mm	30mm	60	15.300min ⁻¹	10*	2,30
72049	50mm	30mm	80	15.300min ⁻¹	10*	2,30
72050	50mm	30mm	120	15.300min ⁻¹	10*	2,30
72051	60mm	40mm	40	12.700min ⁻¹	10*	3,50
72052	60mm	40mm	60	12.700min ⁻¹	10*	3,50
72053	60mm	40mm	80	12.700min ⁻¹	10*	3,50
72054	60mm	40mm	120	12.700min ⁻¹	10*	3,50
72055	80mm	50mm	40	9.550min ⁻¹	10*	6,00
72056	80mm	50mm	60	9.550min ⁻¹	10*	6,00
72057	80mm	50mm	80	9.550min ⁻¹	10*	6,00
72058	80mm	50mm	120	9.550min ⁻¹	10*	6,00

NEW

- Za finiširanje, matiranje i čišćenje velike palete metalnih proizvoda
- Idealno za brušenje sitnih delova i odlivaka, unutrašnjih površina u cevima, delovima i nepristupačnim segmentima
- Može da se koristi i za vlažno i suvo brušenje
- Pogodno za upotrebu na ravnoj brusilici
- Prečnik osovine 6mm

BRUSNI VALJAK
SA OSOVINOM, NETKANI

ŠIFRA	PREČNIK	VISINA	GRANUL.	MAX RPM	KUTIJA	€/KOM.
72059	40mm	25mm	120	15.000min ⁻¹	10*	1,50
72060	40mm	25mm	180	15.000min ⁻¹	10*	1,50
72061	40mm	25mm	280	15.000min ⁻¹	10*	1,50
72062	50mm	30mm	120	12.000min ⁻¹	10*	1,80
72063	50mm	30mm	180	12.000min ⁻¹	10*	1,80
72064	50mm	30mm	280	12.000min ⁻¹	10*	1,80
72065	60mm	40mm	120	10.000min ⁻¹	10*	2,20
72066	60mm	40mm	180	10.000min ⁻¹	10*	2,20
72067	60mm	40mm	280	10.000min ⁻¹	10*	2,20
72068	80mm	50mm	120	7.200min ⁻¹	10*	3,70
72069	80mm	50mm	180	7.200min ⁻¹	10*	3,70
72070	80mm	50mm	280	7.200min ⁻¹	10*	3,70

*KOLIČINA PRI VIŠESTRUKOJ PORUČBINI

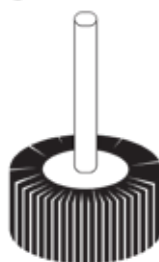
NEW

**BRUSNI VALJAK
 SA OSOVINOM, KOMBINOVANI**

ŠIFRA	PREČNIK	VISINA	GRANUL.	MAX RPM	KUTIJA	€/KOM.
72071	50mm	30mm	100	25.400min ⁻¹	10*	1,80
72072	50mm	30mm	150	25.400min ⁻¹	10*	1,80
72073	50mm	30mm	320	25.400min ⁻¹	10*	1,80
72074	60mm	40mm	100	25.400min ⁻¹	10*	2,20
72075	60mm	40mm	150	19.100min ⁻¹	10*	2,20
72076	60mm	40mm	320	19.100min ⁻¹	10*	2,20
72077	80mm	50mm	100	19.100min ⁻¹	10*	3,70
72078	80mm	50mm	150	19.100min ⁻¹	10*	3,70
72079	80mm	50mm	320	15.300min ⁻¹	10*	3,70

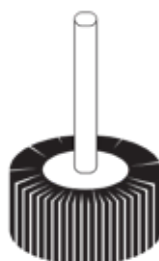

- Za fino brušenje matiranje, za ravnomerno finišenje
- Dizajnirano za upotrebu na svim vrstama metala
- Idealno za brušenje sitnih delova i odlivaka, unutrašnjih površina u cevima, delovima i nepristupačnim segmentima
- Može da se koristi i za blago skidanje ostataka
- Pogodno za upotrebu na ravnoj brusilici
- Prečnik osovine 6mm

NEW

**BRUSNI VALJAK
 SA OSOVINOM, FILC**

ŠIFRA	PREČNIK	VISINA	MAX RPM	KUTIJA	€/KOM.
72103	30mm	20mm	19.000min ⁻¹	10*	2,80
72104	50mm	30mm	12.000min ⁻¹	10*	4,60
72105	80mm	50mm	7.200min ⁻¹	10	14,00



- Za prethodno poliranje do savršenog sjajnog finišenja na malim i srednje veličine delovima
- Sa malim termičkim opterećenjem na predmetu rada
- Uvek koristite pastu za poliranje
- Pogodno za upotrebu na ravnoj brusilici
- Prečnik osovine 6mm

*KOLIČINA PRI VIŠESTRUKOJ PORUDŽBINI

NEW



**BRUSNI DISK ZA TVRDI BETON,
TURBO-JET**

ŠIFRA	PREČNIK	RUPU Ø	MAX RPM	POGODAN ZA	€/KOM.
72393	125mm	22,2mm	12.250min ⁻¹	BRUSILICE ZA BETON	99,00
72394	180mm	22,2mm	8.500min ⁻¹	BRUSILICE ZA BETON	119,00

- Idealno za brušenje betona i površina sa mineralnim premazima
- Sa 2 reda zuba sa dijamantima koji obezbeđuju tihi rad, dug radni vek i dobru završnu obradu

NEW MUST HAVE



BRUSNI DISK ZA MEKI BETON

ŠIFRA	PREČNIK	RUPU Ø	MAX RPM	POGODAN ZA	€/KOM.
71998	115mm	M14	13.300min ⁻¹	MOTORNE BRUSILICE	85,00

- Savršeno za:
Brušenje ili ravnanje svežeg mekog betona i lakog betona,
Uklanjanje ispupčenja ili nesavršenosti pri livenju svežeg betona,
Razbijanje ivica na strukturama od svežeg betona,
Brušenje tvrdog cementa sa velikim procentom peska,
Brušenje lepka za pločice na malteru,
Uklanjanje lepka za pločice sa lakog betona,
Šmirglanje lakog betona i premaza na podovima

NEW BEST SELLER MUST HAVE



BRUSNI DISK ZA MEKI BETON

ŠIFRA	PREČNIK	RUPU Ø	MAX RPM	POGODAN ZA	€/KOM.
71999	125mm	22,2mm	12.500min ⁻¹	CONCRETE GRINDER	90,00
72000	180mm	22,2mm	8.500min ⁻¹	CONCRETE GRINDER	107,00

- Savršeno za:
Brušenje ili ravnanje svežeg mekog betona i lakog betona,
Uklanjanje ispupčenja ili nesavršenosti pri livenju svežeg betona,
Razbijanje ivica na strukturama od svežeg betona,
Brušenje tvrdog cementa sa velikim procentom peska,
Brušenje lepka za pločice na malteru,
Uklanjanje lepka za pločice sa lakog betona,
Šmirglanje lakog betona i premaza na podovima

*KOLIČINA PRI VIŠESTRUKOJ PORUČBINI

NEW

BETON

LONG LIFE
**BRUSNI DISK ZA BETON,
TURBO-JET**

ŠIFRA	PREČNIK	RUPU Ø	MAX RPM	POGODAN ZA	€/KOM.
72392	115mm	M14	13.300min ⁻¹	MOTORNE BRUSILICE	74,00

- Stari beton, svježi (zeleni)
- Idealno za površinsko mlevenje na mineralnim supstratima
- Sa velikim brojem zuba koji obezbeđuju znatno tiše operativne performanse, duži život i atraktivniji obrazac šmirglanja

NEW
MUST HAVE

BETON

LONG LIFE
BRUSNI DISK ZA TVRDI BETON

ŠIFRA	PREČNIK	RUPU Ø	MAX RPM	POGODAN ZA	€/KOM.
72001	115mm	M14	13.300min ⁻¹	MOTORNE BRUSILICE	89,00

- Savršeno za:
Šmirglanje starog i tvrdog betona, tvrdog gipsa sa cementim i epoksidnim premazima. Sa inovativnim dizajnom koji kombinuje efikasno šmirglanje i maksimalni vek trajanja,
Osvežavanje površine betona,
Uklanjanje ispupčenja ili nesavršenosti pri livenju preko starog betona,
Šmirglanje tvrdog cementnog maltera,
Pogrubljivanje postojećeg sloja pločica pre postavljanja novog,
Uklanjanje stvrdnutih premaza od epoksidne smole,
Uklanjanje staklaste površine i drugih premaza na betonu

NEW
BEST SELLER
MUST HAVE

BETON

LONG LIFE
BRUSNI DISK ZA TVRDI BETON

ŠIFRA	PREČNIK	RUPU Ø	MAX RPM	POGODAN ZA	€/KOM.
72002	125mm	22,2mm	12.250min ⁻¹	BRUSILICE ZA BETON	95,00
72003	180mm	22,2mm	8.500min ⁻¹	BRUSILICE ZA BETON	112,00

- Savršeno za:
Šmirglanje starog i tvrdog betona, tvrdog gipsa sa cementim i epoksidnim premazima. Sa inovativnim dizajnom koji kombinuje efikasno šmirglanje i maksimalni vek trajanja,
Osvežavanje površine betona,
Uklanjanje ispupčenja ili nesavršenosti pri livenju preko starog betona,
Šmirglanje tvrdog cementnog maltera,
Pogrubljivanje postojećeg sloja pločica pre postavljanja novog,
Uklanjanje stvrdnutih premaza od epoksidne smole,
Uklanjanje staklaste površine i drugih premaza na betonu

MUST TRY

- Sa zrcima od 100% cirkonija
- Njegov poseban sastav sprečava porast temperature površina za brušenje, dajući duži vek trajanja disku, čak i na najtvrdim površinama od nerđajućeg čelika i pod najzahtjevnijim uslovima rada
- Na bazi fiber vlakana od mešavine pamuka i poliestera
- Idealan za upotrebu u teškoj industriji i brodogradnji



**CIRKONSKI DISK
SA VLAKNIMA, 125 mm**

ŠIFRA	GRAN-UL.	KOMBINIRATI S	KUTIJA	€/KOM.
71805	24	74340, 74341, 74343	25*	0,98
71806	36	74340, 74341, 74343	25*	0,84
71807	40	74340, 74341, 74343	25*	0,64
71808	60	74340, 74341, 74343	25*	0,60
71809	80	74340, 74341, 74343	25*	0,54



MUST TRY

- Sa zrcima od 100% cirkonija
- Njegov poseban sastav sprečava porast temperature površina za brušenje, dajući duži vek trajanja disku, čak i na najtvrdim površinama od nerđajućeg čelika i pod najzahtjevnijim uslovima rada
- Na bazi fiber vlakana od mešavine pamuka i poliestera
- Idealan za upotrebu u teškoj industriji i brodogradnji



**CIRKONSKI DISK
SA VLAKNIMA, 150 mm**

ŠIFRA	GRAN-UL.	KOMBINIRATI S	KUTIJA	€/KOM.
71810	24	74340, 74341, 74343	25*	1,50
71811	36	74340, 74341, 74343	25*	1,30
71812	60	74340, 74341, 74343	25*	0,88
71813	80	74340, 74341, 74343	25*	0,82



MUST TRY

- Sa zrcima od 100% keramike
- Njegov poseban sastav sprečava porast temperature površina za brušenje, dajući duži vek trajanja disku, čak i na najtvrdim površinama od nerđajućeg čelika i pod najzahtjevnijim uslovima rada
- Na bazi fiber vlakana od mešavine pamuka i poliestera
- Idealan za upotrebu u teškoj industriji i brodogradnji



**KERAMIČKI DISK
SA VLAKNIMA, 125 mm**

ŠIFRA	GRAN-UL.	KOMBINIRATI S	KUTIJA	€/KOM.
71814	24	74340, 74341, 74343	25*	1,44
71815	36	74340, 74341, 74343	25*	1,38
71816	40	74340, 74341, 74343	25*	1,10



MUST TRY

- Sa zrcima od 100% keramike
- Njegov poseban sastav sprečava porast temperature površina za brušenje, dajući duži vek trajanja disku, čak i na najtvrdim površinama od nerđajućeg čelika i pod najzahtjevnijim uslovima rada
- Na bazi fiber vlakana od mešavine pamuka i poliestera
- Idealan za upotrebu u teškoj industriji i brodogradnji



**KERAMIČKI DISK
SA VLAKNIMA, 150 mm**

ŠIFRA	GRAN-UL.	KOMBINIRATI S	KUTIJA	€/KOM.
71817	24	74340, 74341, 74343	25*	2,20
71818	36	74340, 74341, 74343	25*	2,10
71819	40	74340, 74341, 74343	25*	1,70



*KOLIČINA PRI VIŠESTRUKOJ PORUČBNI

NEW **MUST HAVE**

ČETVOROSTRANI BRUSNI BLOK

ŠIFRA	GRANUL.	KUTIJA	€/KOM.
72221	36	50*	0,80
72222	60	50*	0,80
72223	100	50*	0,80
72224	180	50*	0,80

- Idealno za gipsane ploče, drvo, metal, plastiku i farbane površine
- Fleksibilan, lak za držanje
- Nadmašuje po učinku tradicionalni brusni papir
- Jednostavan za rad u nepristupačnim područjima
- Sa lakim odvajanjem boja, u zavisnosti od granulacije
- Ne sadrži razredjivače
- Dimenzije: 100x68x25mm

NEW **MUST HAVE**

ČETVOROSTRANI BRUSNI BLOK, JEDAN UGAO

ŠIFRA	GRANUL.	KUTIJA	€/KOM.
72225	60	50*	1,10
72226	100	50*	1,10
72227	180	50*	1,10

- Idealno za gipsane ploče, drvo, metal, plastiku i farbane površine
- Fleksibilan, lak za držanje
- Nadmašuje po učinku tradicionalni brusni papir
- Jednostavan za rad u nepristupačnim područjima
- Sa lakim odvajanjem boja, u zavisnosti od granulacije
- Ne sadrži razredjivače
- Dimenzije: 125x90x25mm

NEW **MUST HAVE**

DVOSTRANA BRUSNA PODLOGA

ŠIFRA	GRANUL.	KUTIJA	€/KOM.
72228	60	50*	0,70
72229	120	50*	0,70
72230	220	50*	0,70

- Idealno za finalnu obradu metala i brušenje kontura
- Jedinstveni penasti sastav
- Nadmašuje po učinku tradicionalni brusni papir
- Otporan na cepanje
- Koristi se za suvo i mokro brušenje
- Ne sadrži razredjivače
- Dimenzije: 123x98x25mm

NEW

JEDNOSTRANA BRUSNA PODLOGA

ŠIFRA	GRANUL.	KUTIJA	€/KOM.
72231	60	50*	0,70
72232	120	50*	0,70
72233	220	50*	0,70
72234	400	50*	0,70

- Idealno za finalnu obradu metala i brušenje kontura
- Jedinstveni penasti sastav
- Nadmašuje po učinku tradicionalni brusni papir
- Otporan na cepanje
- Koristi se za suvo i mokro brušenje
- Ne sadrži razredjivače
- Dimenzije: 140x115x25mm



*KOLIČINA PRI VIŠESTRUKOJ PORUČBINI

NEW



INOX

**ČELIČNA ŽIČANA
ČETKA-LONAC M14**

ŠIFRA	PREČNIK	MAX RPM	KUTIJA	€/KOM.
72404	65mm	12.500min ⁻¹	5	6,20
72405	85mm	8.500min ⁻¹	5	8,80
72406	100mm	8.500min ⁻¹	5	11,80

- Idealno za deburiranje, uklanjanje rđe, uklanjanje farbe, blendanje ivica
- Pogodan za brusilicu

NEW



INOX

**ČELIČNA ŽIČANA
ČETKA-LONČASTA UPLETENA M14**

ŠIFRA	PREČNIK	MAX RPM	KUTIJA	€/KOM.
72407	65mm	12.500min ⁻¹	5	9,20
72408	80mm	8.500min ⁻¹	5	15,50

- Idealno za deburiranje, uklanjanje rđe, uklanjanje farbe, blendanje ivica
- Pogodan za brusilicu

NEW



INOX

**ČELIČNA ŽIČANA
ČETKA-TANJIRASTA M14**

ŠIFRA	PREČNIK	MAX RPM	KUTIJA	€/KOM.
72409	115mm	12.500min ⁻¹	5	9,20

- Idealno za isušivanje, uklanjanje rđe, čišćenje površina
- Pogodan za brusilicu

NEW



INOX

**ČELIČNA ČETKA-TANJIRASTA
UPLETENA M14**

ŠIFRA	PREČNIK	MAX RPM	KUTIJA	€/KOM.
72411	115mm	12.500min ⁻¹	5	12,00

- Idealno za isušivanje, uklanjanje rđe, čišćenje površina
- Pogodan za brusilicu

NEW



INOX

ČETKA PLETENA ROTACIONA M14

ŠIFRA	PREČNIK	MAX RPM	KUTIJA	€/KOM.
72416	115mm	12.500min ⁻¹	5	12,50

- Idealno za isušivanje, uklanjanje rđe, čišćenje površina
- Pogodan za brusilicu

NEW



INOX

KRUŽNA ČETKA ČELIČNA

ŠIFRA	PREČNIK	RUPU Ø	MAX RPM	KUTIJA	€/KOM.
72418	125mm	20mm	8.500min ⁻¹	5	19,00
72419	150mm	32mm	6.000min ⁻¹	5	23,00

- Idealno za isušivanje, uklanjanje rđe, čišćenje površina
- Pogodan za mašinu za mlevenje duplih točkova

*KOLIČINA PRI VIŠESTRUKOJ PORUDŽBINI

NEW **INOX**



ČELIČNA ČETKICA SA PRIHVATOM Ø6mm

ŠIFRA	PREČNIK	MAX RPM	KUTIJA	€/KOM.
72421	12mm	20.000min ⁻¹	20	2,80
72422	17mm	4.500min ⁻¹	20	5,00
72423	25mm	4.500min ⁻¹	20	5,50

- Pogodan za energetska bušilicu

NEW **INOX**



ČELIČNA ČETKICA PLETENA SA PRIHVATOM Ø6mm

ŠIFRA	PREČNIK	MAX RPM	KUTIJA	€/KOM.
72420	22mm	20.000min ⁻¹	20	7,00

- Pogodan za energetska bušilicu

NEW **INOX**



ČELIČNA ŽIČANA ČETKA-LONAC SA PRIHVATOM Ø6mm

ŠIFRA	PREČNIK	MAX RPM	KUTIJA	€/KOM.
72427	50mm	4.500min ⁻¹	12	3,40
72428	75mm	4.500min ⁻¹	12	4,40

- Idealno za deburiranje, uklanjanje rđe, uklanjanje farbe, blendanje ivica
- Pogodan za energetska bušilicu

NEW **INOX**



ČELIČNA ŽIČANA ČETKA-LONAC SA PRIHVATOM Ø6mm

ŠIFRA	PREČNIK	MAX RPM	KUTIJA	€/KOM.
72424	50mm	12.000min ⁻¹	12	5,50
72425	60mm	12.000min ⁻¹	12	7,20
72426	70mm	12.000min ⁻¹	12	8,40

- Idealno za isušivanje, uklanjanje rđe, čišćenje površina
- Pogodno za ravnu brusilicu

NEW **INOX**



KRUŽNA ČETKA ČELIČNA SA PRIHVATOM Ø6mm

ŠIFRA	PREČNIK	DEBLJINA	MAX RPM	KUTIJA	€/KOM.
72438	50mm	6mm	4.500min ⁻¹	12	2,50
72439	75mm	9mm	4.500min ⁻¹	12	3,40
72440	100mm	10mm	4.500min ⁻¹	12	4,20

- Idealno za deburiranje, uklanjanje rđe, uklanjanje farbe, blendanje ivica
- Pogodan za energetska bušilicu

NEW **INOX**



KRUŽNA ČETKA ČELIČNA SA PRIHVATOM Ø6mm

ŠIFRA	PREČNIK	DEBLJINA	MAX RPM	KUTIJA	€/KOM.
72430	30mm	6mm	20.000min ⁻¹	12	4,50
72431	40mm	9mm	18.000min ⁻¹	12	4,60
72432	50mm	10mm	15.000min ⁻¹	12	5,10
72434	60mm	10mm	15.000min ⁻¹	12	5,90

- Idealno za deburiranje, uklanjanje rđe, uklanjanje farbe, blendanje ivica
- Pogodno za ravne brusilice i pneumatske mašine

NEW **INOX**



KRUŽNA ČETKA ČELIČNA SA PRIHVATOM Ø6mm

ŠIFRA	PREČNIK	DEBLJINA	MAX RPM	KUTIJA	€/KOM.
72433	50mm	15mm	15.000min ⁻¹	12	6,60
72435	60mm	15mm	15.000min ⁻¹	12	7,40
72436	70mm	15mm	15.000min ⁻¹	12	9,20
72437	80mm	15mm	12.000min ⁻¹	12	12,00

- Idealno za deburiranje, uklanjanje rđe, uklanjanje farbe, blendanje ivica
- Pogodno za ravnu brusilicu

BEST SELLER **MUST HAVE**

**ČELIČNA ŽIČANA
 ČETKA-LONAC M14**

ŠIFRA	PREČNIK	MAX RPM	KUTIJA	€/KOM.
74307	65mm	12.500min ⁻¹	5	4,30
74308	85mm	8.500min ⁻¹	5	6,00
74309	100mm	8.500min ⁻¹	5	8,50
74310	125mm	6.500min ⁻¹	5	12,00
74311	150mm	4.500min ⁻¹	5	16,00

BEST SELLER **MUST HAVE**

**ČELIČNA ŽIČANA ČETKA-LONČASTA
 UPLETENA M14**

ŠIFRA	PREČNIK	MAX RPM	KUTIJA	€/KOM.
74317	65mm	12.500min ⁻¹	5	11,00
74318	80mm	8.500min ⁻¹	5	16,00
74320	100mm	8.500min ⁻¹	5	22,00
74321	125mm	6.500min ⁻¹	5	32,00

BEST SELLER **MUST HAVE**

**ČELIČNA ŽIČANA
 ČETKA-TANJIRASTA M14**

ŠIFRA	PREČNIK	MAX RPM	KUTIJA	€/KOM.
74312	100mm	12.500min ⁻¹	10	5,50
74313	115mm	12.500min ⁻¹	10	6,50
74314	125mm	12.500min ⁻¹	10	7,50

BEST SELLER **MUST HAVE**

**ČELIČNA ČETKA-TANJIRASTA
 UPLETENA M14**

ŠIFRA	PREČNIK	MAX RPM	KUTIJA	€/KOM.
74315	100mm	12.500min ⁻¹	10	9,00
74316	125mm	12.500min ⁻¹	10	12,00

NEW

**ČETKA ŽIČANA ROTACIONA
 UPLETENA M14**

ŠIFRA	PREČNIK	MAX RPM	KUTIJA	€/KOM.
72417	115mm	12.500min ⁻¹	5	7,20

- Idealno za isušivanje, uklanjanje rđe, čišćenje površina
- Pogodan za brusilicu

NEW

**ČETKA ŽIČANA ROTACIONA
 UPLETENA**

ŠIFRA	PREČNIK	RUPU Ø	MAX RPM	KUTIJA	€/KOM.
72413	115mm	22,2mm	12.500min ⁻¹	5	0,00

- Idealno za isušivanje, uklanjanje rđe, čišćenje površina
- Pogodan za brusilicu

BEST SELLER **MUST HAVE**

 VISOKI O/
 MIN

**ČELIČNA ČETKICA HIGH RPM
 SA PRIHVATOM Ø6mm**

ŠIFRA	PREČNIK	MAX RPM	KUTIJA	€/KOM.
72451	12mm	20.000min ⁻¹	20	1,80
74329	17mm	20.000min ⁻¹	20	2,50
74330	25mm	20.000min ⁻¹	20	3,40
72452	30mm	20.000min ⁻¹	20	3,70

- Pogodno za bušilice, ravne brusilice i pneumatske mašine

NEW

 VISOKI O/
 MIN

**ČELIČNA ČETKICA PLETENA HIGH RPM
 SA PRIHVATOM Ø6mm**

ŠIFRA	PREČNIK	MAX RPM	KUTIJA	€/KOM.
72450	22mm	20.000min ⁻¹	20	4,00

- Pogodno za bušilice, ravne brusilice i pneumatske mašine

NEW

 VISOKI O/
 MIN

**ČELIČNA ŽIČANA ČETKA-LONAC HIGH RPM
 SA PRIHVATOM Ø6mm**

ŠIFRA	PREČNIK	MAX RPM	KUTIJA	€/KOM.
72441	50mm	12.000min ⁻¹	12	3,20
72442	60mm	12.000min ⁻¹	12	4,10
72443	70mm	12.000min ⁻¹	12	5,00

- Idealno za uklanjanje opiljaka, rđe, boje i završnu bradu površine
- Pogodno za ravne brusilice i pneumatske mašine

BEST SELLER **MUST HAVE**

**ČELIČNA ŽIČANA ČETKA-LONAC
 SA PRIHVATOM Ø6mm**

ŠIFRA	PREČNIK	MAX RPM	KUTIJA	€/KOM.
74304	50mm	12.000min ⁻¹	36	2,80
74305	75mm	10.000min ⁻¹	36	3,60
74306	80mm	4.500min ⁻¹	36	4,50

BEST SELLER **MUST HAVE**

 VISOKI O/
 MIN

**KRUŽNA ČETKA ČELIČNA HIGH RPM
 SA PRIHVATOM Ø6mm**

ŠIFRA	PREČNIK	DEBLJINA	MAX RPM	KUTIJA	€/KOM.
74300	40mm	8mm	20.000min ⁻¹	12	1,90
74301	50mm	8mm	20.000min ⁻¹	12	2,00
72445	60mm	10mm	15.000min ⁻¹	12	2,70
74302	75mm	12mm	20.000min ⁻¹	12	2,80
74303	100mm	12mm	20.000min ⁻¹	12	3,30

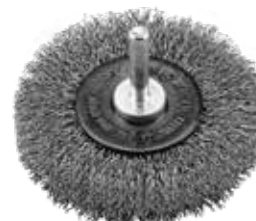
NEW

 VISOKI O/
 MIN

**KRUŽNA ČETKA ČELIČNA HIGH RPM
 SA PRIHVATOM Ø6mm**

ŠIFRA	PREČNIK	DEBLJINA	MAX RPM	KUTIJA	€/KOM.
72444	50mm	15mm	15.000min ⁻¹	12	3,80
72446	60mm	15mm	15.000min ⁻¹	12	4,30
72447	70mm	15mm	15.000min ⁻¹	12	5,40
72448	80mm	15mm	15.000min ⁻¹	12	7,00

- Idealno za uklanjanje opiljaka, rđe, boje i završnu bradu površine
- Pogodno za bušilice, ravne brusilice i pneumatske mašine

NEW



VISOKI O/
MIN

**ČETKA PLETENA ROTACIONA HIGH RPM
SA PRIHVATOM Ø6mm**

ŠIFRA	PREČNIK	MAX RPM	KUTIJA	€/KOM.
72449	75mm	15.000min ⁻¹	12	4,30

- Idealno za uklanjanje opiljaka, rđe, boje i završnu bradu površine
- Pogodno za ravne brusilice i pneumatske mašine



**ŽIČANA KRUŽNA
ČETKA-KOVRDŽAVA ŽICA**

ŠIFRA	PREČNIK	RUPE Ø	MAX RPM	KUTIJA	€/KOM.
74326	125mm	20mm	8.500min ⁻¹	5	8,00
74327	150mm	32mm	8.500min ⁻¹	5	12,00

- Prečnik 16mm sa elastičnim prstenom
- Pakovanje sadrži adaptore za prilagodjavanje svim vrstama dvostranih brusilica



BEST
SELLER MUST
HAVE



VISOKI O/
MIN

**KOMPLET ŽIČANA ČETKA, MALA,
SA PRIHVATOM Ø2,3mm, 3 KOM**

ŠIFRA	PREČNIK	MAX RPM	KUTIJA	€/SET
74331	6mm	25.000min ⁻¹	12	3,50

- Pogodno za dremel, dodatke za bušilicu itd.



**BEST
SELLER** **MUST
HAVE**



RUČNA ČETKA

ŠIFRA	KUTIJA	€/KOM.
74359	24*	1,60

MADE IN
ITALY



SPIRALNA ŽIČANA ČETKA Ø28mm

ŠIFRA	PREČNIK	MAX RPM	KUTIJA	€/KOM.
74328	28mm	2.000min ⁻¹	10	2,90

• Za cevi 3/4"-1"

*KOLIČINA PRI VIŠESTRUKOJ PORUČBINI





**PLOČASTA ČETKA, NAJLON,
SA PRIHVATOM Ø6mm**

ŠIFRA	PREČNIK	MAX RPM	KUTIJA	€/KOM.
74322	75mm	4.500min ⁻¹	5	7,20
74323	100mm	4.500min ⁻¹	5	8,60



**LONČASTA ČETKA, NAJLON,
SA PRIHVATOM Ø6mm**

ŠIFRA	PREČNIK	MAX RPM	KUTIJA	€/KOM.
74324	50mm	4.500min ⁻¹	5	7,10
74325	70mm	4.500min ⁻¹	5	8,90



**DISK SA PAMUČNOM OBLOGOM
SA DUPLOM ŽICOM SA OTVOROM**

ŠIFRA	PREČNIK	RUPU Ø	KUTIJA	€/KOM.
74367	100mm	20mm	20	4,00
74368	120mm	20mm	20	4,40

**MUST
HAVE**



**DISK SA PAMUČNOM OBLOGOM
SA PRIHVATOM Ø6mm**

ŠIFRA	PREČNIK	KUTIJA	€/KOM.
74366	80mm	12	4,00

**MUST
HAVE**



GUMENA PODLOGA

ŠIFRA	PREČNIK	KOMBINIRATI S	KUTIJA	€/KOM.
74338	125mm	74468	25	3,80
74339	180mm	74469	15	5,30



• Koristi se kao podloga za krzno za poliranje

**MUST
HAVE**

**100%
NATURAL
WOOL**



**KRPA ZA ZAVRŠNO
POLIRANJE
SA VELCRO TIPOM**

ŠIFRA	PREČNIK	KUTIJA	€/KOM.
71959	115mm	450	6,20
71960	125mm	400	7,00
71961	150mm	280	9,20

• Za završno poliranje

**MUST
HAVE**

**100%
NATURAL
WOOL**



**KRPA ZA ZAVRŠNO
POLIRANJE SA KANAPOM**

ŠIFRA	PREČNIK	POGODAN ZA	KUTIJA	€/KOM.
74468	140mm	74338	300	8,00
74469	190mm	74339	200	12,00

• Za završno poliranje

*KOLIČINA PRI VIŠESTRUKOJ PORUČBINI

BEST SELLER **MUST HAVE**



KLJUČ ZA BRUSILICU PODESIVI

ŠIFRA	OTVOR ČELJUSTI	KUTIJA	€/KOM.
24743	20mm/35mm	10	4,40



KLJUČ ZA BRUSILICU

ŠIFRA	OTVOR ČELJUSTI	KUTIJA	€/KOM.
24742	35mm	10	3,20



BEST SELLER **MUST HAVE**



KLJUČ ZA STEZNU GLAVU BUŠILICE

ŠIFRA	PREČNIK	KUTIJA	€/KOM.
74355	10-13mm	20	2,30



BEST SELLER **MUST HAVE**



ZAKRIVLJENA PRSTENASTA MATICA

ŠIFRA	RUPE Ø	KUTIJA	€/KOM.
74065	M14	64	4,00



MUST HAVE



RAVNA PRSTENASTA MATICA

ŠIFRA	RUPE Ø	KUTIJA	€/KOM.
74085	M14	64	4,00



PLASTIC
WOOD
CHIPBOARD



- 80 zubaca
- Veličina otvora od 13-16-20 mm
- 7000 br. obrt./minuti
- Sa 2 podesiva prstena
- Pogodan za duplu brusilicu & kružnu testeru

LIST ZA CIRKULARNU TESTERU ZA DRVO I PLASTIKU

ŠIFRA	PREČNIK	KUTIJA	€/KOM.
74360	125mm	50	6,20

MUST HAVE



POTPORNI VIJAK ZA VELCRO ČIČAK PODLOGU M14, 10 KOM

ŠIFRA	KUTIJA	€/PAK.
33675	50	18,00

*KOLIČINA PRI VIŠESTRUKOJ PORUČBINI

**BEST
SELLER** **MUST
HAVE**



**PLASTIČNA PODLOGA
ZA POLIRANJE VELCRO TIP, M14**

ŠIFRA	PREČNIK	DEBLJINA	MAX RPM	KUTLIJA	€/KOM.
37695	115mm	10mm	13.000min ⁻¹	60	8,30
37696	125mm	10mm	12.000min ⁻¹	60	8,60
37697	150mm	10mm	10.000min ⁻¹	50	11,10

- Gustina: Srednja
- Za brušenje krivih površina

**MUST
HAVE**



**FLEKSIBILNA PLASTIČNA PODLOGA
ZA POLIRANJE VELCRO TIP, M14**

ŠIFRA	PREČNIK	MAX RPM	KUTLIJA	€/KOM.
37678	125mm	12.000min ⁻¹	80	6,00
37679	150mm	10.000min ⁻¹	50	8,80

- Gustina: Veoma meka
- Za sunder



PU PODLOGA ZA POLIRANJE VELCRO TIP ,M14

ŠIFRA	PREČNIK	DEBLJINA	MAX RPM	KUTLIJA	€/KOM.
37657	115mm	12mm	7.500min ⁻¹	50	11,50
37661	125mm	12mm	7.000min ⁻¹	50	12,70
37676	150mm	12mm	5.500min ⁻¹	50	15,60

- Gustina: Srednja
- Za velcro tip brusne diskove



**PLASTIČNA CRNA PODLOGA
ZA POLIRANJE VELCRO TIP, M14**

ŠIFRA	PREČNIK	DEBLJINA	MAX RPM	KUTLIJA	€/KOM.
37698	125mm	18mm	7.000min ⁻¹	50	15,90
37699	150mm	18mm	6.000min ⁻¹	50	18,90

- Gustina: Veoma meka



**TVRDA PODLOGA
ZA POLIRANJE VELCRO TIP, M14**

ŠIFRA	PREČNIK	DEBLJINA	MAX RPM	KUTLIJA	€/KOM.
37654	150mm	3mm	10.000min ⁻¹	50	19,30

- Gustina: Srednja/tvrd
- Za sunder
- Efikasno na krivim površinama

BENMAN[®]
PROFESSIONAL TOOLS

MUST HAVE

**SUNĐER ZA POLIRANJE,
VELCRO TIP, NARANDŽAST**

ŠIFRA	PREČNIK	DEBLJINA	MAX RPM	KUTIJA	€ /KOM.
37710	150mm	25mm	4.500min ⁻¹	60	5,10
37711	150mm	50mm	4.500min ⁻¹	30	7,30

- Gustina: Tvrdra

MUST HAVE

**SUNĐER ZA POLIRANJE,
VELCRO TIP, ANTRACIT**

ŠIFRA	PREČNIK	DEBLJINA	MAX RPM	KUTIJA	€ /KOM.
37712	150mm	50mm	3.500min ⁻¹	30	7,90

- Gustina: Srednja

MUST HAVE

**SUNĐER ZA POLIRANJE
SA VELCRO ČIČAK TRAKOM**

ŠIFRA	PREČNIK	DEBLJINA	MAX RPM	KUTIJA	€ /KOM.
37709	150mm	25mm	3.500min ⁻¹	50	6,20

- Gustina: Veoma meka
- Pogodno za završno poliranje

**SUNĐER ZA POLIRANJE,
ANTRACIT, M14**

ŠIFRA	PREČNIK	DEBLJINA	MAX RPM	KUTIJA	€ /KOM.
37708	150mm	50mm	3.500min ⁻¹	30	9,50

- Gustina: Srednja

BEST SELLER MUST HAVE

SUNĐER ZA POLIRANJE, NARANDŽASTI, M14

ŠIFRA	PREČNIK	DEBLJINA	MAX RPM	KUTIJA	€ /KOM.
37707	150mm	50mm	4.500min ⁻¹	30	9,40

- Gustina: Tvrdra

BEST SELLER MUST HAVE

VIŠESLOJNI SUNĐER ZA POLIRANJE, M14

ŠIFRA	PREČNIK	DEBLJINA	MAX RPM	KUTIJA	€ /KOM.
74348	125mm	45mm	3.000min ⁻¹	10	13,00
74349	175mm	45mm	3.000min ⁻¹	10	14,00

- Pogodno za brusilicu i bušilicu M14

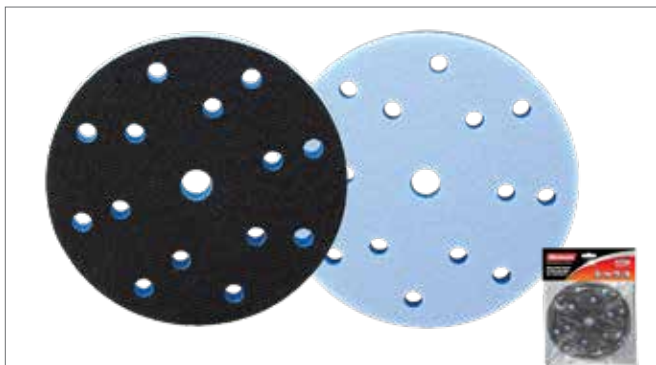

MEĐUPODLOGA

ŠIFRA	PREČNIK	DEBLJINA	RUPE	MAX RPM	KUTIJA	€/KOM.
37713	150mm	12mm	15	10.000min ⁻¹	100	6,10

- Gustina: Meka



**DUAL ACTION KRUŽNA PODLOGA
ZA ŠMIRGLU VELCRO TIP**

ŠIFRA	PREČNIK	DEBLJINA	RUPE	POGODAN ZA	MAX RPM	KUTIJA	€/KOM.
37700	125mm	12mm	8	M8 & 5/16"	12.000min ⁻¹	50	14,60
37701	150mm	12mm	6	5/16"	10.000min ⁻¹	50	17,00

- Gustina: Srednja
- Umetak: Stakleno vlakno
- Za brušenje ravnih i krivih površina
- M8 pogodan za Festo brusilice
- 5/16" pogodan za sve brusilice



**DUAL ACTION KRUŽNA PODLOGA
ZA ŠMIRGLU VELCRO, M8 & 5/16" SA POLIMEROM**

ŠIFRA	PREČNIK	DEBLJINA	RUPE	POGODAN ZA	MAX RPM	KUTIJA	€/KOM.
37702	150mm	12mm	15	M8 & 5/16"	12.000min ⁻¹	50	19,40

- Gustina: Srednja
- Umetak: Polimer
- M8 pogodan za Festo, Makita brusilice
- 5/16" pogodan za sve brusilice

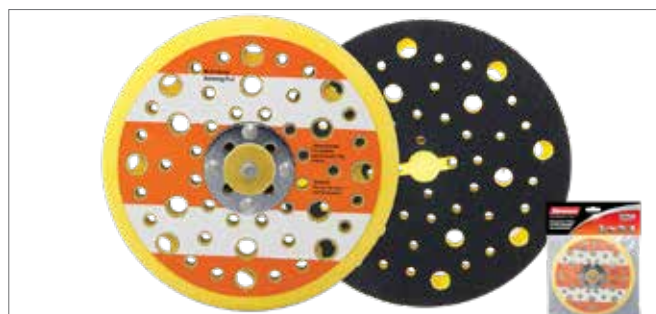

**DUAL ACTION KRUŽNA PODLOGA
ZA ŠMIRGLU VELCRO TIP 5/16"**

ŠIFRA	PREČNIK	DEBLJINA	RUPE	POGODAN ZA	MAX RPM	KUTIJA	€/KOM.
37703	150mm	12mm	53	5/16"	10.000	50	21,60

- Gustina: Srednja
- Umetak: Polimer
- 5/16" pogodan za sve brusilice



**DUAL ACTION KRUŽNA PODLOGA
ZA ŠMIRGLU VELCRO, M8 & 5/16", SREDNJA**

ŠIFRA	PREČNIK	DEBLJINA	MAX RPM	POGODAN ZA	KUTIJA	€/KOM.
37704	150mm	8mm	12.000min ⁻¹	M8 & 5/16"	50	24,90

- Gustina: Srednja
- M8 pogodan za Festo, Makita brusilice
- 5/16" pogodan za sve brusilice



PROFESIONALNA

**DUAL ACTION KRUŽNA PODLOGA
ZA ŠMIRGLU VELCRO, M8 & 5/16", SREDNJA/TVRDA**

ŠIFRA	PREČNIK	DEBLJINA	RUPE	MAX RPM	POGODAN ZA	KUTIJA	€/KOM.
37705	150mm	12mm	15	12.000min ⁻¹	M8 & 5/16"	50	24,10

- Gustina: Srednja/tvrda
- M8 pogodan za Festo brusilice
- 5/16" pogodan za sve brusilice

*KOLIČINA PRI VIŠESTRUKOJ PORUČBINI

**BEST
SELLER** **MUST
HAVE**



PLASTIČNA PODLOGA M14 BEZ VIJKA

ŠIFRA	PREČNIK	KOMBINIRATI S	KUTIJA	€ /KOM.
74340	115mm	74065	30	2,30
74341	125mm	74065	25	2,70
74343	180mm	74065	20	3,40

- Koristi se kao osnova za vlaknasti disk



PROFILISANI, RUČNI BLOK, VELCRO TIP

ŠIFRA	DUŽINA	KUTIJA	€ /KOM.
37706	150mm	75	8,60

- Ergonomski dizajn
- Idealno za konveksne i konkavne površine

**MUST
HAVE**



BRUSNI TOČAK

ŠIFRA	PREČNIK	RUPE Ø	DEBLJINA	KUTIJA	€ /KOM.
74336	125mm	16mm	16mm	10	5,60
74337	150mm	16mm	20mm	10	7,00

**MUST
HAVE**



KAMEN ZA OŠTRENJE

ŠIFRA	DUŽINA	KUTIJA	€ /KOM.
74333	230mm	20	2,90

NEW **NICE
TO HAVE**



FLEKSIBILNI NASTAVAK ZA BUŠILICU-ODVIJAČ

ŠIFRA	DUŽINA	KUTIJA	€ /KOM.
72403	300mm	12	9,00

- Idealno za bušenje uskih i teško dostižnih prostora
- Utičnica: 1/4"



FLEKSIBILNO POGONSKO VRATILO 6mm

ŠIFRA	DUŽINA	KUTIJA	€ /KOM.
74350	900mm	20	22,00

*KOLIČINA PRI VIŠESTRUKOJ PORUDŽBINI

NEW MUST HAVE



**ČELIČNA ČETKA
ZA ČIŠĆENJE DIMNJAKA,
SPLJOŠTENA, OKRUGLA**

ŠIFRA	PREČNIK	KUTIJA	€/KOM.
18025	150mm	6	6,20
18026	200mm	6	6,60
18027	250mm	6	7,00
18028	300mm	6	8,00

- Idealno za čišćenje dimnjaka, stvara savršenu promaju
- Sprečava dimnjake da se pale i smanjuje emisiju ugljen-monoksida



NEW MUST HAVE



**ČELIČNA ČETKA
ZA ČIŠĆENJE DIMNJAKA,
SPLJOŠTENA, ČETVRTASTA**

ŠIFRA	DUŽINA	KUTIJA	€/KOM.
18030	200mm	6	8,60
18031	250mm	6	9,00
33016	300mm	6	10,00

- Idealno za čišćenje dimnjaka, stvara savršenu promaju
- Sprečava dimnjake da se pale i smanjuje emisiju ugljen-monoksida



NEW



**NAJLONSKA ČETKA
ZA CEVI, OKRUGLA**

ŠIFRA	PREČNIK	KUTIJA	€/KOM.
18029	300mm	6	10,00

- Idealno za dimnjake od nerđajućeg čelika



NEW MUST HAVE



**CRVENA DRŠKA
ZA ČETKU ZA CEVI**

ŠIFRA	DUŽINA	KUTIJA	€/KOM.
18032	1m	25	3,70
18033	2m	25	5,40



*KOLIČINA PRI VIŠESTRUKOJ PORUČBINI

NEW MUST HAVE



UVRNUTE ČETKE ZA CEVI

ŠIFRA	PREČNIK	KUTIJA	€/KOM.
18034	20mm	20	3,50
18035	25mm	20	3,70
18036	30mm	20	3,80
18037	40mm	20	4,00
18038	50mm	20	4,20
18039	60mm	20	4,40
18040	70mm	20	4,60
18041	80mm	5	4,80
18042	100mm	5	5,20
18043	120mm	5	5,40



NEW MUST HAVE



FLEKSIBILNA DRŠKA ZA ČETKU ZA CEVI

ŠIFRA	DUŽINA	€/KOM.
18044	1m	26,00
18045	1,5m	31,00



NEW



KOMPLET FLEKSIBILNIH ČETKI ZA CEVI

ŠIFRA	DUŽINA	KUTIJA	€/KOM.
72453	3m	10	16,00

- Idealno za šporete i oluke
- Komplet sadrži fleksibilnu cev 3m i malu četku 80mm

*KOLIČINA PRI VIŠESTRUKOJ PORUČBINI



GARTNER RETAIL GROUP DOO

Nemanjina 20 34000 Kragujevac

034/6101443 064/8661097

info@gartner.rs www.gartner.rs